

## **NEMA Standards Publication TC 14-2002**

### *Reinforced Thermosetting Resin Conduit (RTRC) and Fittings*

*Published by*

**National Electrical Manufacturers Association**

1300 North 17th Street  
Rosslyn, Virginia 22209

[www.nema.org](http://www.nema.org)

NEMA (National Electrical Manufacturers Association) has adopted UL 1684 Standard for Safety for Reinforced Thermosetting Resin Conduit (RTRC) and Fittings on October 18, 2002 as NEMA Standard Number TC 14-2002. The publications of revised pages or a new edition of this UL Standard will not invalidate NEMA adoption.

UL shall not be responsible for the use or reliance upon a UL Standard by anyone. UL shall not incur any obligation or liability for damages, including consequential damages, arising out of or in connection with the use, interpretation, or reliance upon a UL Standard.

UL 1684 is adopted, with permission, from Underwriters Laboratories Inc. and is Copyrighted by Underwriters Laboratories Inc.

Revisions of UL Standards for Safety are issued from time to time. A UL Standard for Safety is current only if it incorporates the most recently adopted revisions. Copies of current editions of UL Standards may be purchased from: Comm2000 1418 Brook Drive, Downers Grove, IL 60515-- Telephone: 1-888-853-3512 in U.S. or Canada or 415-352-2168 outside the U.S. and Canada: Fax 1-888-853-3512 in U.S. and Canada or 1-630-932-7387 outside the U.S. and Canada; <http://www.comm-2000.com>.

---

Underwriters Laboratories Inc. (UL)  
333 Pfingsten Road  
Northbrook, IL 60062-2096

UL Standard for Safety for Reinforced Thermosetting Resin Conduit (RTRC) and Fittings, UL 1684

Third Edition, Dated March 17, 2000

UL is in the process of converting its Standards for Safety to the Standard Generalized Markup Language (SGML), and implementing an SGML compliant document management and publishing system. SGML - an international standard (ISO 8879-1986) - is a descriptive markup language that describes a document's structure and purpose, rather than its physical appearance on a page. Significant benefits that will result from UL's use of SGML and these new systems include increased productivity, reduced turnaround times, and data and information consistency, reusability, shareability, and portability. However, the fonts, pagination, and general formatting of UL's new electronic publishing system differ from that of UL's previous publishing system. Consequently, when revision pages are issued for a Standard with the new publishing system, these differences may result in the printing of pages on which no requirements have been changed - these additional pages result from relocation of text due to repagination and reformatting of the Standard with the new publishing system.

Announcement Bulletin(s): This Standard contains the announcement bulletin(s) dated April 4, 1996. The announcement bulletin is located at the end of the Standard.

The master for this Standard at UL's Northbrook Office is the official document insofar as it relates to a UL service and the compliance of a product with respect to the requirements for that product and service, or if there are questions regarding the accuracy of this Standard.

UL's Standards for Safety are copyrighted by UL. Neither a printed copy of a Standard, nor the distribution diskette for a Standard-on-Diskette and the file for the Standard on the distribution diskette should be altered in any way. All of UL's Standards and all copyrights, ownerships, and rights regarding those Standards shall remain the sole and exclusive property of UL.

All rights reserved. No part of this publication may be reproduced, stored in a retrieval system, or transmitted in any form by any means, electronic, mechanical photocopying, recording, or otherwise without prior permission of UL.

Revisions of UL Standards for Safety are issued from time to time. A UL Standard for Safety is current only if it incorporates the most recently adopted revisions.

UL provides this Standard "as is" without warranty of any kind, either expressed or implied, including but not limited to, the implied warranties of merchantability or fitness for any purpose.

In no event will UL be liable for any special, incidental, consequential, indirect or similar damages, including loss of profits, lost savings, loss of data, or any other damages arising out of the use of or the inability to use this Standard, even if UL or an authorized UL representative has been advised of the possibility of such damage. In no event shall UL's liability for any damage ever exceed the price paid for this Standard, regardless of the form of the claim.

UL will attempt to answer support requests concerning electronic versions of its Standards. However, this support service is offered on a reasonable efforts basis only, and UL may not be able to resolve every support request. UL supports the electronic versions of its Standards only if they are used under the conditions and operating systems for which it is intended. UL's support policies may change from time-to-time without notification.

---

UL reserves the right to change the format, presentation, file types and formats, delivery methods and formats, and the like of both its printed and electronic Standards without prior notice.

Purchasers of the electronic versions of UL's Standards for Safety agree to defend, indemnify, and hold UL harmless from and against any loss, expense, liability, damage, claim, or judgement (including reasonable attorney's fees) resulting from any error or deviation introduced while purchaser is storing an electronic Standard on the purchaser's computer system.

If a single-user version electronic Standard was purchased, one copy of this Standard may be stored on the hard disk of a single personal computer, or on a single LAN file-server or the permanent storage device of a multiple-user computer in such a manner that this Standard may only be accessed by one user at a time and for which there is no possibility of multiple concurrent access.

If a multiple-user version electronic Standard was purchased, one copy of the Standard may be stored on a single LAN file-server, or on the permanent storage device of a multiple-user computer, or on an Intranet server. The number of concurrent users shall not exceed the number of users authorized.

Electronic Standards are intended for on-line use, such as for viewing the requirements of a Standard, conducting a word search, and the like. Only one copy of the Standard may be printed from each single-user version of an electronic Standard. Only one copy of the Standard may be printed for each authorized user of a multiple-user version of an electronic Standard. Because of differences in the computer/software/printer setup used by UL and those of electronic Standards purchasers, the printed copy obtained by a purchaser may not look exactly like the on-line screen view or the printed Standard.

An employee of an organization purchasing a UL Standard can make a copy of the page or pages being viewed for their own fair and/or practical internal use.

The requirements in this Standard are now in effect, except for those paragraphs, sections, tables, figures, and/or other elements of the Standard having future effective dates as indicated in the note following the affected item. The prior text for requirements that have been revised and that have a future effective date are located after the Standard, and are preceded by a "SUPERSEDED REQUIREMENTS" notice.

New product submittals made prior to a specified future effective date will be judged under all of the requirements in this Standard including those requirements with a specified future effective date, unless the applicant specifically requests that the product be judged under the current requirements. However, if the applicant elects this option, it should be noted that compliance with all the requirements in this Standard will be required as a condition of continued Listing, Recognition, and Follow-Up Services after the effective date, and understanding of this should be signified in writing.

Copyright © 2000 Underwriters Laboratories Inc.

This Standard consists of pages dated as shown in the following checklist:

Page	Date
1-38 .....	March 17, 2000
A1-A2 .....	March 17, 2000
B1-B6 .....	March 17, 2000

Canadian Standards Association  
CAN/CSA C22.2 No. 211.3-96  
*Fourth Edition*

Underwriters Laboratories Inc.  
UL 1684  
*Third Edition*



## **Reinforced Thermosetting Resin Conduit (RTRC) and Fittings**

March 17, 2000

## **Commitment for Amendments**

This Standard is issued jointly by Canadian Standards Association and Underwriters Laboratories Incorporated. Amendments to this Standard will be made only after processing according to the Standards writing procedures by both Canadian Standards Association and Underwriters Laboratories Incorporated.

**ISSN 0317-5669**

**Copyright © 1996  
Canadian Standards Association**  
*All rights reserved. No part of this  
publication may be reproduced in any  
form, in an electronic retrieval system  
or otherwise, without the prior  
permission of the publisher.*

**ISBN 0-7629-0086-5**

**Copyright © 2000  
Underwriters Laboratories Inc.**

## CONTENTS

Preface .....	4
Foreword (CSA) .....	5
Foreword (UL) .....	6

### Reinforced Thermosetting Resin Conduit (RTRC) and Fittings

1 Scope .....	7
2 Definitions .....	7
3 Reference publications and units of measurement .....	7
4 Construction .....	9
4.1 General .....	9
4.4 Elbows .....	9
4.5 Adapters .....	10
4.6 Conduit bodies .....	10
5 Qualification tests .....	10
5.2 Compression (conduit) .....	10
5.4 Impact resistance at low temperature (conduit) .....	11
5.6 Water absorption (conduit) .....	12
5.7 Chemical resistance (optional) .....	12
5.8 Joint water tightness .....	14
5.9 Joint separation .....	14
5.10 Flattening resistance (conduit) .....	14
5.11 Resistance to sag (for above ground conduit only) .....	15
5.12 Flame retardant properties (for above ground conduit only) .....	15
5.13 Vertical flame (FT4) conduit on cable tray (not mandatory) .....	17
5.16 Weather resistance (for above ground conduit only) .....	20
5.17 Infrared spectroscopy .....	22
5.19 Durability of printing (all types with surface-applied markings of ink, dyes, etc.) .....	23
5.21 External icing (conduit bodies) .....	24
6 Marking .....	25
7 In factory tests .....	25

### Appendix A – Guidelines

A3 Intake airflow .....	A1
-------------------------	----

### Appendix B – Method to determine the halogen content of a low halogen material using the calculation method from pH and Acid Gas Evolution

B3 Test equipment .....	B1
B4 Test procedure .....	B2
B4.4 Acid gas measurement .....	B3
B5 Determination of halogen content .....	B3

## Preface

This is the fourth edition of the Standard for Reinforced Thermosetting Resin Conduit (RTRC) and Fittings, published under the dual designation C22.2 No. 211.3 and the third edition of published UL 1684. This Standard supersedes the previous editions of C22.2 No. 211.3 published in 1993, 1990 and 1984, and also supersedes the previous edition of UL 1684.

The main changes from the 1993 edition of C22.2 No. 211.3 are:

- a) Definitions are added;
- b) Requirements for conduit bodies are included;
- c) Chemical resistance test becomes optional (to meet the requirements of the specific environment where the conduit is to be installed);
- d) Details of the tests for weather resistance and flame are included to ensure that the Standard is self-contained as much as possible;
- e) Infrared spectroscopy and durability of printing tests are added.

The main changes from the second edition of UL 1684 are:

- a) Editorial corrections for clarification;
- b) Revisions to Table 10 (Maximum vertical deflection of the diameter on the resistance to flattening test) to correct deflection values.

This common Standard was prepared by a Joint Task Force comprised of NEMA/CSA/UL members and includes:

<b>Richard Candahl</b>	United Fiberglass of America Inc., Springfield, Ohio, USA	<i>Chair</i>
<b>Goran Hag</b>	Champion Fiberglass Inc., Spring, Texas, USA	
<b>Phil Ellsworth</b>	Smith Fiberglass Products Inc., Wichita, Kansas, USA	
<b>Dora Carter</b>	National Electrical Manufacturers Association, Washington, D.C., USA	
<b>Greg Nieminski</b>	Underwriters Laboratories Inc., Melville New York, USA	
<b>Steve Paniri</b>	Canadian Standards Association, Etobicoke, Ontario	<i>Administrator</i>

This Standard was also approved by the CSA Technical Committee on Wiring Products and has been processed according to the method of development, revision, and implementation of UL Standards for safety.

This Standard will be approved as a National Standard of Canada by the Standards Council of Canada and will be submitted to the American National Standards Institute for publication as an American National Standard.

March 17, 2000

---

## Foreword (CSA)

Certification organizations, as accredited by the Standards Council of Canada, have their own criteria procedures for certification services. The following paragraphs define CSA Certification policies.

The Canadian Standards Association provides certification services for manufacturers who, under license from CSA, wish to use the appropriate registered CSA Marks on certain products of their manufacture to indicate conformity with CSA Standards.

CSA Certification for a number of products is provided in the interest of maintaining agreed-upon standards of quality, performance, interchangeability and/or safety, as appropriate. Where applicable, certification may form the basis for acceptance by inspection authorities responsible for enforcement of regulations. Where feasible, programs will be developed for additional products for which certification is desired by producers, consumers or other interests.

In performing its functions in accordance with its objectives, CSA does not assume or undertake to discharge any responsibility of the manufacturer or any other party. The opinions and findings of the Association represent its professional judgement given with due consideration to the necessary limitations of practical operation and state of the art at the time the Standard is processed.

Products in substantial accord with this Standard but which exhibit a minor difference or a new feature may be deemed to meet the Standard providing the feature or difference is found acceptable utilizing appropriate CSA Certification Division Operating Procedures. Products which comply with this Standard shall not be certified if they are found to have additional features which are inconsistent with the intent of this Standard. Products shall not be certifiable if they are discovered to contravene applicable Federal laws or regulations.

Testing techniques, test procedures and instrumentation frequently must be prescribed by the CSA Certification Division in addition to the technical requirements contained in Standards of CSA. In addition to markings specified in the Standard the CSA Certification and Testing Division may require special cautions, markings and instructions that are not specified by the Standard.

Some tests required by CSA Standards may be inherently hazardous. The Association neither assumes nor accepts any responsibility for any injury or damage that may occur during or as the result of tests, wherever performed, whether performed in whole or in part by the manufacturer or the Association, and whether or not any equipment, facility or personnel for or in connection with the test is furnished by the manufacturer or the Association.

Manufacturers should note that, in the event of the failure of the CSA Certification and Testing Division to resolve an issue arising from the interpretation of requirements, there is an appeal procedure: the complainant should submit the matter, in writing, to the Secretary of the Canadian Standards Association.

If this Standard is to be used in obtaining CSA Certification please remember, when making application for certification, to request all current Amendments, Bulletins, Notices and Technical Information Letters that may be applicable and for which there may be slight charge. For such information or for further information concerning details about CSA Certification please address your inquiry to the Applications and Records Section, Canadian Standards Association, 178 Rexdale Boulevard, Etobicoke (Toronto), Ontario M9W 1R3.

## Foreword (UL)

A. This Standard contains basic requirements for products covered by Underwriters Laboratories Inc. (UL) under its Follow-Up Service for this category within the limitations given below and in the Scope section of this Standard. These requirements are based upon sound engineering principles, research, records of tests and field experience, and an appreciation of the problems of manufacture, installation, and use derived from consultation with and information obtained from manufacturers, users, inspection authorities, and others having specialized experience. They are subject to revision as further experience and investigation may show is necessary or desirable.

B. The observance of the requirements of this Standard by a manufacturer is one of the conditions of the continued coverage of the manufacturer's product.

C. A product which complies with the text of this Standard will not necessarily be judged to comply with the Standard if, when examined and tested, it is found to have other features which impair the level of safety contemplated by these requirements.

D. A product employing materials or having forms of construction which conflict with specific requirements of the Standard cannot be judged to comply with the Standard. A product employing materials or having forms of construction not addressed by this Standard may be examined and tested according to the intent of the requirements and, if found to meet the intent of this Standard, may be judged to comply with the Standard.

E. UL, in performing its functions in accordance with its objectives, does not assume or undertake to discharge any responsibility of the manufacturer or any other party. The opinions and findings of UL represent its professional judgment given with due consideration to the necessary limitations of practical operation and state of the art at the time the Standard is processed. UL shall not be responsible to anyone for the use of or reliance upon this Standard by anyone. UL shall not incur any obligation or liability for damages, including consequential damages, arising out of or in connection with the use, interpretation of, or reliance upon this Standard.

F. Many tests required by the Standards of UL are inherently hazardous and adequate safeguards for personnel and property shall be employed in conducting such tests.

---

## Reinforced Thermosetting Resin Conduit (RTRC) and Fittings

### 1 Scope

1.1 This Standard specifies the requirements for halogen-free reinforced thermosetting resin conduit (RTRC), and associated fittings for installation and use in accordance with the Rules of the Canadian Electrical Code, (CEC) Part I, and the National Electrical Code (NEC) for nonhazardous locations.

1.2 The products specified in this Standard are intended for use at, but not limited to, -40°C (-40°F) to 110°C (230°F) continuous operating temperature.

1.3 This Standard covers conduit Type AG for use above ground and/or below ground, and Type BG for use below ground only.

1.4 This Standard covers conduit Type ID (dimensions based on inside diameters) and Type IPS (dimensions based on outside diameters of iron pipe sizes). Trade sizes (metric designators) are 1/2 (16), 3/4 (21), 1 (27), 1-1/4 (35), 1-1/2 (41), 2 (53), 2-1/2 (63), 3 (78), 3-1/2 (91), 4 (103), 4 HW (103), 4-1/2 (116), 5 (129), and 6 (155).

*Note: The values in parenthesis are metric size designations of conduits and fittings and do not necessarily reflect metric trade sizes.*

1.5 Fittings specified in this Standard include, but are not limited to, straight couplings, 5° angle couplings, adapters, elbows with plain ends or integral belled ends at one or both ends, expansion joints and conduit bodies.

*Note: A product that contains features, characteristics, components, materials, or systems new or different from those in use when the Standard was developed, and that involves a risk of fire, electric shock, or injury to persons, shall be evaluated using the appropriate additional component and end-product requirements as determined necessary to maintain the level of safety for the user of the product as originally anticipated by the intent of this Standard.*

### 2 Definitions

2.1 The following definitions apply in this Standard:

**Integral belled end** – a belled end installed at the factory, either integrally wound or a permanently attached coupling

**Conduit body** – a separate portion of a conduit system that provides access through a removable cover(s) to the interior of the system at a junction of two or more sections of the system or at a terminal point of the system.

**Halogen-free** – a material having not more than 0.2 percent by weight of total halogen content.

*Note: For other definitions, refer to NEC and/or CEC.*

### 3 Reference publications and units of measurement

3.1 **Reference publications** Where reference is made to other publications, such reference shall be considered to refer to the latest edition and all amendments published to that edition up to the time when this Standard was approved.

**CSA Standards**

C22.1-1994,  
*Canadian Electrical Code (CEC), Part 1*

C22.2 No. 38-95,  
*Thermoset Insulated Wires and Cables*

CAN/CSA-C22.2 No. 126-M91,  
*Cable Tray Systems*

**ANSI/ASTM<sup>1</sup> Standard**

D256-93A,  
*Test Methods for Impact Resistance of Plastics and Electrical Insulating Materials*

**ANSI/NFPA<sup>2</sup> Standard**

70,  
*National Electrical Code (NEC)*

**ASTM<sup>3</sup> Standards**

D2105-90,  
*Test Method for Longitudinal Tensile Properties of "Fiberglass" (Glass-Fiber-Reinforced Thermosetting-Resin) Pipe and Tube*

G23-93,  
*Practice for Operating Light-Exposure Apparatus (Carbon-Arc Type) With and Without Water for Exposure of Nonmetallic Materials*

G26-94,  
*Practice for Operating Light-Exposure Apparatus (Xenon-Arc Type) With and Without Water for Exposure of Nonmetallic Materials*

**CAN/CGSB<sup>4</sup> Standard**

3.14-M88,  
*Liquefied Petroleum Gas (Propane)*

## UL<sup>5</sup> Standard

44-1991,  
*Rubber Insulated Wires and Cables.*

<sup>1</sup>American National Standards Institute/American Society for Testing and Materials.

<sup>2</sup>American National Standards Institute/National Fire Protection Association.

<sup>3</sup>American Society for Testing and Materials.

<sup>4</sup>Canadian General Standards Board.

<sup>5</sup>Underwriters Laboratories Inc.

**3.2 Units of measurement** Where a value for measurement is followed by a value in other units in parentheses, the second value may be only approximate. The first stated value is the requirement.

## 4 Construction

### 4.1 General

4.1.1 Only materials that are acceptable for the particular use shall be employed.

4.1.2 Conduit and fittings shall be fiber impregnated with a cured thermosetting resin compound. The conduit shall have a uniform wall, a smooth interior, and shall not contain any features that can damage wiring installed in the conduit.

4.1.3 Conduit shall be straight and both ends of each length of conduit shall be perpendicular to the longitudinal axis of the conduit.

4.1.4 Integral and nonintegral connections shall provide a mechanically secure and watertight joint.

**4.2 Conduit with an integral belled end** The dimensions of conduit with an integral coupling on one end shall be in accordance with the values specified in Tables 1 and 2. They shall also meet the requirements of Clause 5.8.

**4.3 Couplings** Couplings shall be straight with belled ends, or 5° angle couplings. Dimensions of couplings are shown in Tables 3 and 4. Couplings shall also meet the requirements of Clause 5.8.

### 4.4 Elbows

4.4.1 Elbows shall be provided with plain ends or have an integral belled end at one or both ends. Elbows shall also meet the requirements of Clause 5.8.

4.4.2 The radius and dimension of an elbow are shown in Table 5 and Figure 1.

4.4.3 The straight end portions (see dimension  $L_s$  on Figure 1) of an elbow shall be at least 13 mm (1/2 in) longer than the socket depth.

## 4.5 Adapters

**4.5.1 Threaded adapters and threaded box connectors** Adapters for joining conduit to other threaded systems shall be as specified in Table 6.

**4.5.2 Other adapters** Other adapters shall meet the joint separation requirements specified in Clause 5.8. They shall also meet the requirements of Clause 5.8.

**4.5.3 Bore of conduit and elbows** The internal diameter of a finished elbow shall be such that a round ball or an equivalent mandrel will pass freely through the bore of the conduit and elbow. The diameter of the ball or equivalent mandrel shall be 90 percent of the original internal diameter for conduit and 85 percent of the original internal diameter for elbows.

As an alternative to using a ball to check the bore of conduit and bends, an inside micrometer gauge or a telescopic gauge and a micrometer caliper may be used.

## 4.6 Conduit bodies

**4.6.1 Material** Conduit bodies shall be of reinforced thermosetting resin material which provides flame and mechanical properties consistent with the conduit system.

**4.6.2 Covers** Conduit bodies shall be furnished with a blank cover. Threaded inserts may be molded into or assembled into the body.

**4.6.3 Capacity** Conduit bodies constructed to permit a change in direction of axis of conduit system shall have a minimum distance inside the body  $L_m$ , not less than 3 times the trade size of the largest conduit for which the body is designed when measured along the centroid axis from hub to hub. (See Figure 2.)

**4.6.4 Performance** Conduit bodies are intended for use in indoor and outdoor applications, and to provide protection against corrosion, dust, rain, hose directed water and ice. They are not intended to provide protection against internal condensation or internal icing. They shall be subjected to the hosedown test specified in Clause 5.20, and the external icing test specified in Clause 5.21.

## 5 Qualification tests

**5.1 Conditioning** Unless specified otherwise in the description of the test, all specimens shall be preconditioned for at least 24 hours in still air at a temperature of  $23.0 \pm 2.0^\circ\text{C}$  ( $73.4 \pm 3.6^\circ\text{F}$ ).

### 5.2 Compression (conduit)

**5.2.1 General** The internal diameter of conduit shall not decrease by more than 25 percent during application of the force specified in Table 7 when tested in accordance with Clauses 5.2.2 to 5.2.4. The conduit shall show no evidence of cracking or buckling after removal from the compression machine.

**5.2.2 Apparatus** The apparatus for this test shall consist of:

- a) An inside micrometer or telescopic gauges and a micrometer caliper;
- b) a compression machine having 2 steel platens at least 150 mm (6.0 in) long and 10 mm (0.4 in) thick, and capable of running at a speed within the range of 10 – 15 mm/min (0.4 – 0.6 in/min).

5.2.3 **Specimens** The specimens shall consist of three  $150 \pm 3$  mm ( $6.0 \pm 0.125$  in) lengths of conduit.

5.2.4 **Procedure** The inside diameter of the specimen shall be measured and recorded. The specimen shall be placed between the plates of the compression machine such that the measured inside diameter is perpendicular to the platens. The machine shall be set in motion until the force specified in Table 7 has been applied to the specimen. The machine shall be stopped and the inside diameter remeasured. The percent decrease in the internal diameter shall be calculated and recorded.

5.3 **Beam strength (conduit)** The ultimate beam strength of conduit shall not be less than that specified in Table 8 when tested in accordance with Clauses 5.3.1 and 5.3.2.

5.3.1 **Apparatus** The apparatus for this test shall consist of:

- a) Two rigidly supported V-blocks carefully aligned on a free span. (See Figure 3). The angle of the "V" shall be  $120 \pm 3^\circ$ ;
- b) A suitable testing machine having a speed of 10 – 15 mm/min (0.4 – 0.6 in/min); and
- c) A flexible strap having a width of  $50 \pm 3$  mm ( $2.0 \pm 0.125$  in).

5.3.2 **Procedure**

5.3.2.1 The flexible strap shall be placed around the conduit specimen at the center of the span and attached to the testing machine.

5.3.2.2 The testing machine shall be set in motion, and the force at initial yield shall be recorded.

5.4 **Impact resistance at low temperature (conduit)**

5.4.1 When tested in accordance with Clauses 5.4.2 and 5.4.3, there shall not be any fracture or break in the laminate surface of seven out of ten 200 mm (8.0 in) specimens of the finished conduit. A fracture or break is considered to have occurred where a broken section of the laminate forms a protrusion within the inside diameter or extends beyond the outside diameter of the conduit. The portions of the conduit within 50 mm (2.0 in) from the cut ends of the specimen shall not be examined.

5.4.2 The specimens are to be cut from finished lengths of each trade size of conduit. The specimens, the test apparatus, and the surrounding air are to be in thermal equilibrium with one another at a temperature of  $-40 \pm 1^\circ\text{C}$  ( $-40 \pm 1^\circ\text{F}$ ) during the test. Each specimen is to be tested separately while resting on a solid, flat steel plate that is at least 13 mm (1/2 in) thick and is firmly anchored with its upper surface horizontal. A protective cage is to surround the plates and the specimen to reduce the likelihood of injury.

*Exception: When it is necessary to remove the specimen from the low temperature chamber due to handling difficulties, the impact test shall commence as soon as possible and shall be completed within 15 seconds from the time of removal.*

5.4.2 revised March 17, 2000

5.4.3 The impact energy is to be provided by a weight of 9 kg (20 lbs) in the form of a 51 mm (2.0 in) solid right-circular, steel cylinder with a flat impact face having rounded edges, as shown in Figure 4, falling freely through a vertical guide with the impact force as specified in Table 9. The flat face of the weight is to strike the center of the specimen. Provision is to be made for keeping the weight from striking the specimen more than once.

**5.5 Laminate separation in boiling water (conduit)** Conduit shall not show any signs of disintegration or separation into layers when a  $150 \pm 3$  mm ( $6 \pm 0.125$  in) length specimen is immersed in boiling tap water for 1 hour. After removal from the water, the specimen shall be wiped dry and allowed to cool to room temperature. The specimen shall be examined for signs of disintegration and layer separation.

### **5.6 Water absorption (conduit)**

5.6.1 Conduit shall not absorb water more than 0.25 per cent of its weight while immersed for 24 hours in distilled water when tested in accordance with Clause 5.6.2.

5.6.2 The cut edges of a specimen are to be sealed with epoxy cement. The cement is to cure at room temperature for 24 hours. Specimens are to be preconditioned by drying in a full-draft circulation-air oven at a temperature of  $50 \pm 3^\circ\text{C}$  ( $122 \pm 5^\circ\text{F}$ ) for 24 hours, after which they are to remain in still air at a temperature of  $23 \pm 2^\circ\text{C}$  ( $73 \pm 4^\circ\text{F}$ ) for 24 hours.

Following conditioning, the specimen is to be weighed " $W_1$ " to be within 5 mg of balance, and is then to be immersed in distilled water for 24 hours at a temperature of  $23 \pm 2^\circ\text{C}$  ( $73 \pm 4^\circ\text{F}$ ). The specimen is then to be removed from the water, dried quickly inside and out with a clean piece of soft lintless cloth, and immediately reweighed " $W_2$ " within 5 mg of balance.  $W_2/W_1$  shall not be larger than 1.0025.

When a specimen is known to contain or is suspected of containing an appreciable amount of water-soluble material, two specimens are to be preconditioned by drying in a full-draft circulating-air oven at a temperature of  $50 \pm 1^\circ\text{C}$  ( $122 \pm 2^\circ\text{F}$ ) for 24 hours; cooled in a desiccator for 24 hours, and immediately weighed " $W_1$ ". The specimens are then to be immersed in distilled water for 24 hours with the water at a temperature of  $23 \pm 2^\circ\text{C}$  ( $73 \pm 4^\circ\text{F}$ ). Immediately following this immersion, the specimens are to be reconditioned for 24 hours in the oven at  $50 \pm 3^\circ\text{C}$  ( $122 \pm 5^\circ\text{F}$ ), cooled in a desiccator for 24 hours, and immediately reweighed " $W_2$ ".

### **5.7 Chemical resistance (optional)**

5.7.1 Conduit and any adhesive system used to bond lengths of conduit shall be subjected to the tests in Clauses 5.7.2 to 5.7.10. The results of the test on any trade size of conduit shall be considered representative of the performance of the whole size range.

*Exception: Conduit not marked in accordance with Clause 6.4 does not require this test.*

5.7.2 After being exposed to the reagents indicated by the manufacturer at the intended concentration and temperature for 90 days, the crush strength of specimens of the finished conduit shall not be reduced by more than 15 percent, nor shall the specimens experience a change in weight of more than 2.5 percent. Where there is more than 1.0 percent change in weight after 90 days of exposure to the reagent, that change shall not be more than 1.65 times the change in weight measured after 30 days of exposure to the reagent. There shall not be any softening or disintegration of the specimens as a result of exposure to the reagents.

*Note: Usually, a reagent is understood to be a substance used to produce a characteristic reaction in chemical analysis. For the purpose of this Standard, however, it is convenient to consider the word in the less restrictive sense of any chemical, oil, or other substance that has a corrosive or degrading influence on conduit or conduit products.*

5.7.3 Twelve 50 mm (2 in) long specimens are to be used for each reagent. Each specimen is to be cut from clean lengths of the finished conduit and cleaned of loose particles and ragged edges. The edges of all specimens are to be coated with the same resin used to fabricate the conduit. Each specimen is to be weighed " $W_1$ " prior to being immersed in the test solution. Six additional specimens are to be prepared and set aside for comparison purposes during the crush test.

---

*Note: Cautionary measures such as eye protection, gloves and clothing protection are to be used throughout the procedure.*

5.7.4 The weighed specimens are each to be immersed in the reagents in separate, covered containers that do not react with the reagent. Each container is to be filled with the reagent at the intended concentration and temperature to the depth necessary to completely cover the specimens that are placed in it. When the liquid comes to rest in each container, the containers are to be closed and kept at the intended temperature for 30 days without agitation of the reagent.

5.7.5 After 30 days, half of the specimens are to be removed from the reagent, rinsed with clean cold water and carefully wiped dry inside and out with a clean piece of lint-free, absorbent cloth. Each of the six dried specimens is to be reweighed " $W_2$ " to within 10 mg of balance and compared to the original weight " $W_1$ " of the specimen.  $W_2$  shall not be greater than 1.025 times  $W_1$ .

5.7.6 The six specimens immersed for 30 days and the specimens set aside for testing unaged are to be in thermal equilibrium with one another, the testing machine, and the surrounding air at a temperature of  $23 \pm 2^\circ\text{C}$  ( $73 \pm 3^\circ\text{F}$ ) throughout the test. The inside diameter of each specimen is to be measured. The specimens are then to be tested separately between a pair of rigid, flat steel plates that are at least 150 mm (6 in) long and are horizontal and parallel to one another. One plate is to be moved toward the other at the rate of  $12.7 \pm 3.2$  mm/min ( $0.5 \pm 0.125$  in/min):

- a) Until the surface of the specimen pulls away from contact with either plate – that is, until the specimen buckles or
- b) Until the minor axis measured inside the flattening specimen is 60 percent of the inside diameter measured before the test.

5.7.7 The crushing loads at the buckling and 60 percent points are to be noted on the dial on the machine and recorded for each specimen. The loads at each of these points for the aged specimens are each to be divided by the average loads at each of these points for the unaged specimens. The resulting ratios shall not be less than 0.85 and no conditioned specimen shall crack or collapse before buckling or the 60 percent point is reached.

5.7.8 The six remaining specimens are to remain immersed for an additional 60 days at the intended temperature. After the full 90 days, the specimens are to be removed from the reagent, rinsed, and dried as noted in Clause 5.7.6 before being reweighed. The dried specimens are each to be weighed " $W_3$ " to within 10 mg of balance.

- a)  $W_3$  shall not be greater than 1.025 times  $W_1$ .
- b) The ratio of  $W_3$  to  $W_1$  shall not be more than 1.00 and the ratio of  $(W_3 - W_1)$  to  $(W_2 - W_1)$  shall not be greater than 1.65.

5.7.9 The specimens immersed for 90 days are to be in thermal equilibrium with the testing machine, and the surrounding air at a temperature of  $23 \pm 2^\circ\text{C}$  ( $73 \pm 4^\circ\text{F}$ ). The inside diameter of each specimen is to be measured. The specimens are to be tested separately between a pair of rigid, flat steel plates that are at least 150 mm (6 in) long and are horizontal and parallel to one another. One plate is to be moved toward the other at the rate of  $12.7 \pm 3.2$  mm/min ( $0.5 \pm 0.125$  in/min):

- a) Until the surface of the specimen pulls away from contact with either plate – that is, until the specimen buckles or
- b) Until the minor axis measured inside the flattening specimen is 60 percent of the inside diameter measured before the test.

5.7.10 The crushing loads at the buckling and the 60 percent points are to be noted from the dial on the machine and recorded for each specimen. The loads at each of these points are to be averaged for the set of six specimens. The average loads at each of these points for the immersed specimens are to be divided by the average loads at each of these points for the unaged specimens. The resulting ratios shall not be less than 0.85 and no conditioned specimen shall crack or collapse before buckling or the 60 percent point is reached.

## **5.8 Joint water tightness**

5.8.1 Coupled conduit and expansion joints shall not leak when tested in accordance with Clause 5.8.2.

*Exception: Expansion joints marked in accordance with Clause 6.2(h) are not required to be subjected to this test.*

5.8.2 A  $300 \pm 3$  mm ( $12.0 \pm 0.125$  in) length of conduit shall be inserted into the integral coupling of another length of conduit having a total length of  $300 \pm 3$  mm ( $12.0 \pm 0.125$  in), according to the manufacturer's installation instructions.

In the case of a non-integral coupling, two  $300 \pm 3$  mm ( $12.0 \pm 0.125$  in) lengths of conduit shall be inserted into the coupling according to the manufacturer's instructions. One end of the assembly shall be capped with a suitable enclosure. The assembly shall be placed in the vertical position, with the sealed end at the bottom, and filled with tap water. After a minimum of 4 hours, the specimen shall be visually examined to determine any evidence of leakage at the joint.

## **5.9 Joint separation**

5.9.1 A joint (conduit and socket) shall not separate when tested in accordance with Clause 5.9.2.

5.9.2 Two joints in each trade size are to be assembled as intended. A gasketed joint shall be subjected to an axial pull of 444 N (100 lbf), applied to the assembly for 5 min, and tending to pull the conduit out of the socket. A mechanical or threaded joint shall be subjected to an axial pull of 4448 N (1000 lbf), applied to the assembly for 1 min, and tending to pull the conduit out of the socket. An adhesively secured joint shall be subjected to an axial pull of 6670 N (1500 lbf), applied to the assembly for 1 min, and tending to pull the conduit out of the socket.

*Note: See Appendix A, Clause A1 for guidance.*

## **5.10 Flattening resistance (conduit)**

5.10.1 The vertical inside diameter of conduit shall not decrease by more than the value indicated in Table 10 when tested in accordance with Clause 5.10.2.

5.10.2 Two specimens shall be tested. Each specimen shall be  $75 \pm 3$  mm ( $3 \pm 0.125$  in) long. The vertical inside diameter of each specimen shall be measured and the value recorded. The specimens shall be placed horizontally side by side between the 2 steel platens of a static load test as shown in Figure 5. The specimens shall be placed such that the measured vertical inside diameter is in the vertical position. No part of the specimen shall extend beyond either platen. A test mass of 45 kg (100 lb), including the mass of the upper platen, shall be symmetrically applied. This assembly shall be maintained at a temperature of  $110 \pm 1^\circ\text{C}$  ( $230 \pm 2^\circ\text{F}$ ) for a period of 24 hours. The specimens shall be allowed to cool, with the test mass removed, at  $23 \pm 2^\circ\text{C}$  ( $73 \pm 4^\circ\text{F}$ ) for a minimum of 1 hour. The vertical inside diameter shall be remeasured and the actual decrease calculated and recorded.

## 5.11 Resistance to sag (for above ground conduit only)

5.11.1 For a product line of a given construction and material, conduit of trade size 1 (27) shall not sag more than 13 mm (0.5 in) when tested in accordance to Clause 5.11.2. The apparatus for this test shall consist of the following:

- a) A circulating air oven;
- b) A 0.9 kg (2 lb) mass;
- c) A cotton tape having a width of  $19 \pm 3$  mm ( $0.75 \pm 0.125$  in);
- d) A straight edge;
- e) A scale graduated in millimeters (inches); and
- f) Two metal support blocks. The specimen shall consist of a  $560 \pm 3$  mm (22 in  $\pm 0.125$  in) length of conduit.

For product lines of different size or construction, the mass per cross section shall be equal to the mass specified in this Clause.

5.11.2 The support blocks shall be placed in the oven so that they are spaced  $510 \pm 3$  mm ( $22.0 \pm 0.125$  in) apart. The specimen shall be suspended in the horizontal position between the 2 support blocks. The 0.9 kg (2 lb) mass shall be suspended below the conduit by means of the cotton tape. The cotton tape shall be applied around the specimen at the center of the 510 mm (20.0 in) span. The specimen shall be maintained under load in the oven at  $110 \pm 1^\circ\text{C}$  ( $230 \pm 2^\circ\text{F}$ ) for a period of 24 hours. Immediately after the specified time the straight edge shall be placed along the upper surface of the specimen and the amount of sag measured between the bottom of the straight edge and the top of the conduit at the center of span. This measurement shall be made with the 0.9 kg (2 lb) mass still hanging freely from the specimen.

## 5.12 Flame retardant properties (for above ground conduit only)

### 5.12.1 Mandatory flame

5.12.1.1 **Apparatus** The apparatus for this test shall consist of the following:

- a) A test shield of sheet metal approximately 300 mm (12 in) wide, 350 mm (14 in) deep, and 600 mm (24 in) high, open at the top and front, and 2 rigid support clamps for supporting the test specimen in a vertical position;
- b) A Tirrill burner having a bore of  $10 + 1.6 - 0.0$  mm ( $0.4 + 0.060 - 0.0$  in) and a length of  $100 + 5 - 0$  mm ( $4.0 + 0.200 - 0.0$  in) above the primary-air inlets;
- c) A  $20^\circ$  angle block for supporting the burner;
- d) A supply of bottled, technical grade methane or natural gas of approximately  $37 \text{ MJ/m}^3$  (1000 BTU/cu ft) at normal pressure with a suitable regulator and meter for uniform gas flow;
- e) A stopwatch or other suitable timing device; and
- f) Surgical cotton.

### 5.12.1.2 Specimens

5.12.1.2.1 Test specimens shall be the actual conduit, or a plaque having a minimum size of 100 by 150 mm (4.0 by 6.0 in) and a wall thickness not greater than the minimum wall thickness of the conduit.

5.12.1.2.2 When the material is furnished in a range of colors, melt flows, or reinforcements, specimens representing these ranges shall also be provided. When the burning characteristics are not essentially the same for all specimens representing the range, evaluation shall be limited only to the material in the colors, melt flows, and reinforcement contents tested; or additional specimens in intermediate colors, melt flows, and reinforcement contents shall be provided for testing.

5.12.1.2.3 Three specimens of each type shall be available for testing.

### 5.12.1.3 Procedure

5.12.1.3.1 The test shall be made in a still-air test chamber.

5.12.1.3.2 A specimen of the material shall be supported in a vertical position in the test chamber, by 2 rigid support clamps at both vertical edges of the specimen (see Figure 6). A layer of surgical cotton shall be located 300 mm (12 in) below the point of application of the test flame. To form the horizontal layer, a small portion (approximately 13 by 25 mm (0.5 by 1.0 in)) of cotton is to be pulled from the supply and then thinned and spread into a 50 mm (2.0 in) square having a freestanding thickness of 6 mm (0.25 in).

5.12.1.3.3 The height of the flame, with the burner vertical, shall be adjusted to approximately 127 mm (5.0 in) with an inner blue cone approximately 38 mm (1.5 in) high, producing a temperature of  $950 \pm 50^{\circ}\text{C}$  ( $1742 \pm 90^{\circ}\text{F}$ ) at the tip of the inner blue cone at a gas pressure equivalent to the one exerted by a 76 mm (3.0 in) water column.

5.12.1.3.4 The burner shall be tilted to an angle of  $20^{\circ}$  from the vertical and the flame applied to the material under test so that the tip of the inner blue cone of the flame touches the specimen at a point approximately 70 mm (2.75 in) above its lower end. A stop shall be fixed in position as shown in Figure 6 to permit the burner to be returned to the same position, thereby maintaining the initial fixed distance between the forward edge of the barrel of the burner and the initial position of the test specimen.

5.12.1.3.5 The flame shall be brought up to the material so that the vertical plane containing the major axis of the burner barrel is at right angles to the line of approach.

5.12.1.3.6 The flame shall be applied for 15 seconds, and then removed for 15 seconds until five such applications have been made. The flame shall not be reapplied while the material is still burning. When the material burns for more than 30 seconds after any of the first four applications, the test shall be discontinued. When the material burns for more than 15 seconds but less than 30 seconds, the flame shall be immediately reapplied upon cessation of flaming.

5.12.1.3.7 The material shall not support combustion for more than 60 seconds after the fifth application of the test flame.

5.12.1.4 **Results** The following shall be observed and recorded for each specimen:

- a) The duration of flaming after the first, second, third, fourth, and fifth flame applications;
- b) The duration of flaming plus glowing after the fifth application;
- c) Whether or not specimens burn up to the holding clamps;

- d) Whether or not specimens drip flaming particles that ignite the surgical cotton; and
- e) Whether or not any openings or other destruction of the test specimen has occurred, and the maximum diameter probe that will pass through any such openings.

### 5.13 Vertical flame (FT4) conduit on cable tray (not mandatory)

5.13.1 **General** This test shall apply to nonmetallic conduit containing wire and cable, intended for installation inside buildings, and exposed, where permitted (see Appendix A, Clause A2).

*Note: The flame spread of nonmetallic conduit or tubing shall be determined in the same manner as any cable with combustible jacket used inside a building.*

5.13.2 **Type of insulated conductors and conduit fill** The conduit shall contain insulated conductors which do not meet the FT1/VW1 flame rating such as Type RW90 unfilled crosslinked polyethylene meeting the requirements of CSA Standard C22.2 No. 38 or RHH in accordance with UL 44. The conduit fill shall be 40 percent.

#### 5.13.3 Enclosure

5.13.3.1 An enclosure shall be provided to eliminate any external influence on the normal upward draft of the burner flame.

5.13.3.2 The enclosure shall contain a window to permit observation of the fire test.

5.13.3.3 No point of the enclosure, above grade, shall be closer than 1 m (3.3 ft) to the in situ cable tray.

5.13.3.4 The intake fresh airflow shall be sufficient to maintain the oxygen content within the test enclosure as evidenced by the clear visibility of the test flame through the observation window (see Appendix A, Clause A3).

5.13.3.5 The maximum air movement within the enclosure, with only the intake and exhaust openings open, the exhaust fan on, where applicable, and the burner off, shall not exceed 1 m/s (3.3 ft/s), as measured by a vane type anemometer in the following areas:

- a) At the floor level where the burner will be positioned during the test and
- b) 1.5 m (5 ft) above the enclosure floor where the cable tray will be positioned during the test.

5.13.3.6 The temperature of the enclosure and the incoming air shall be at least 5°C (41°F) throughout the test.

#### 5.13.4 Trays

5.13.4.1 A steel, ladder cable tray, conforming to CSA Standard C22.2 No. 126, approximately 0.3 m (12 in) wide, 75 mm (2.5 in) deep, and 3 m (10 ft) long, and with longitudinal openings of 0.2 m (8.0 in), shall be used. The rungs shall be arranged such that the burner flame will impinge on the conduit midway between rungs. (See Appendix A, Clause A4.)

### 5.13.5 Burner

5.13.5.1 The burner shall be a 250 mm (100 in) ribbon-type burner supplied by American Gas Furnace Company, Catalogue No. 10L11-55 or equivalent, with an air/gas Venturi mixer, Catalogue No. 14 – 18 or equivalent.

5.13.5.2 The burner shall be mounted on a stand and placed 20° from the horizontal, burner ports up, with the major axis of the burner ports 300 ±30 mm (12 ±1.2 in) above the enclosure floor during the fire test.

5.13.5.3 A guide shall be attached to the burner or stand such that the leading edge of the burner face may be located quickly and accurately 75 ±5 mm (2.5 ±0.2 in) horizontally away from the nearest surface of the conduit during the burn period of the test.

### 5.13.6 Flowmeters

5.13.6.1 A flowmeter shall be inserted in each of the propane and air lines feeding the burner to measure the flow rates of these gases during the test.

5.13.6.2 The propane flowmeter shall be capable of measuring a flow rate of 2.3 by 10<sup>-4</sup> m<sup>3</sup>/s (3 by 10<sup>-4</sup> yds<sup>3</sup>/s) and the air flowmeter 13.3 by 10<sup>-4</sup> m<sup>3</sup>/s (17.4 by 10<sup>-4</sup> yds<sup>3</sup>/s). Measurements shall be accurate to within 3 percent.

### 5.13.7 Air

5.13.7.1 The air supplied to the burner shall be compressed air, either bottled or supplied through a compressed air system.

5.13.7.2 The dew point of the air shall not be warmer than 0°C (32°F) as measured by a dew point measuring device such as Alnor Model 7000U, No. 1999 or equivalent.

5.13.8 **Propane** The gas supplied to the burner shall be natural grade propane meeting the requirements of CAN/CGSB Standard 3.14-M (Grade 1) and having a heat equivalent of approximately 46.4 MJ/kg (85.0 MJ/m<sup>3</sup> at 20°C, 101 kPa).

### 5.13.9 Gas flows

5.13.9.1 The propane flow shall be 2.3 by 10<sup>-4</sup> m<sup>3</sup>/s (3 by 10<sup>-4</sup> yds<sup>3</sup>/s) when corrected to standard temperature and pressure (20°C, 101 kPa or 68°F, 1 atm). This propane flow will provide a potential heat output of approximately 20 kW. (The actual heat output will be less, due to incomplete combustion of the propane.)

5.13.9.2 The airflow shall be 13.3 by 10<sup>-4</sup> m<sup>3</sup>/s (17.4 by 10<sup>-4</sup> yds<sup>3</sup>/s) when corrected to standard temperature and pressure.

### 5.13.10 Mounting of conduit

5.13.10.1 The minimum length of each conduit specimen shall be 2.3 m (90.5 in). The specimens shall be positioned in a single layer within the center 250 mm (10 in) portion of the cable tray, with one end of each specimen not more than 100 mm (4.0 in) above the bottom end of the cable tray.

Each individual specimen or group of specimens shall be separately attached to the rungs of the cable tray using metal wire ties of suitable size, such that the conductor specimens remain in position throughout the test. There shall be one attachment at 0.2 m (8.0 in) from the bottom end of the cable tray and other attachments at no more than 0.45 m (17.7 in) spacings.

5.13.10.2 The individual specimens shall be attached to the cable tray with spacings one half the diameter of the conduit, except that the spacings shall not exceed 15 mm (0.6 in). The tray loading shall be as shown in Table 11.

5.13.10.3 The prepared assembly shall not be subjected to temperatures below 15°C (60°F) for longer than 10 min immediately before the test.

### 5.13.11 Test procedure

5.13.11.1 The prepared tray shall be positioned vertically inside the enclosure with the open front of the tray facing the front of the enclosure. The upper portion of the tray shall be firmly fixed in position.

5.13.11.2 The burner shall be ignited and gas flows adjusted to the values in Clause 5.13.9, with the burner positioned away from the specimen. The burner, at an angle of 20° from the horizontal, shall then be positioned in front of the tray and  $75 \pm 5$  mm ( $3 \pm 0.2$  in) from the nearest conduit surface. The horizontal dimension shall be determined through the use of the guide specified in Clause 5.13.5.3. The flame shall impinge on the specimens midway between the tray rungs.

5.13.11.3 The burner flame shall impinge on the specimens for a continuous period of 20 min.

5.13.11.4 At the end of the 20 min burn, the burner flame shall be extinguished and the conduit fire (if any) allowed to burn out.

5.13.11.5 The procedure shall be conducted the number of times specified by the testing authority. Each procedure (burn) shall be conducted on untested specimens.

### 5.13.12 Evaluation of damage

5.13.12.1 Conduit damage shall be determined by measuring the distance of char above the horizontal line from the lower edge of the burner face.

5.13.12.2 The limit of char shall be determined on the front face of the most centrally located conduit by pressing against the conduit surface with a sharp object. Where the surface of the conduit changes from a resilient surface to a brittle (crumbling) surface the limit of char has been determined.

5.13.12.3 The conduit damage (char) shall be given to the nearest 50 mm (2.0 in).

5.13.13 **Criterion** The length of the char after completion of the test shall not exceed 1.5 m (5 ft).

*Note: See Appendix A, for overall guidance on this test procedure. See special marking procedures in Clause 6.2 for this case.*

**5.14 Halogen content** The halogen content shall not exceed 0.2 percent by weight, using the calculated method (see Appendix B).

**5.15 Glass transition temperature test** The glass transition temperature shall be a minimum of 110°C (230°F) when tested in accordance with Clauses 5.15.1 to 5.15.3.

5.15.1 Test apparatus shall be differential scanning calorimeter (DSC).

5.15.2 The size of the specimen is limited by the size of the DSC sample pan. All specimens shall be chipped or filed into a fine powder to provide easy weighing and uniform contact with the pan. For any given piece of conduit, a specimen should be taken 0 – 10 mils from the outer surface, as well as 0 – 10 mils from the inner surface. When the conduit has a liner, then a specimen should be taken from the liner as well as the inner and outer edges of the over-wrap.

5.15.3 The maximum heating rate shall be 40°C/min (72°F/min). Run the scan from room ambient temperature to at least 30°C (54°F) above the expected glass transition temperature and no more than 250°C (482°F). Obtain the  $T_{g1}$ , (midpoint of the inflection in the DSC curve). When  $T_{g1}$  is not within 5°C (9°F) of statistically significant value, cool down the DSC and run the same specimen again from room temperature to 20°C (36°F) above  $T_{g1}$  to obtain  $T_{g2}$ .  $T_{g1}$  and  $T_{g2}$  values obtained with the test specimen should be compared to those statistically significant values obtained from typical production product. The measured and typical values should be within 5°C.

#### **5.16 Weather resistance (for above ground conduit only)**

5.16.1 **Weather resistance** Notched specimens prepared from unaged bar samples machined from the finished conduit shall have an average Izod impact strength of at least 27 J/m (0.5 ft-lbf/in) of notch width. Similar specimens prepared from samples conditioned for 720, 1080, and possibly 1440 hours to carbon arc or 1000 hours, 1500 hours and possibly 2000 hours to xenon arc shall have average Izod impact strengths that comply with Table 9. The samples are to be cut and conditioned and the specimens are to be prepared and tested as indicated in Clauses 5.16.2 to 5.16.12.

5.16.2 Longitudinal strips slightly wider than 12.7 mm (0.5 in) are to be cut from straight lengths of finished conduit of the 4 (103), 5 (129), or 6 (155) trade size. To keep the resulting specimens to the same nominal thickness, all of the strips are to be cut from the same trade size of conduit. Each cut is not to be made radially and is to be made in a plane parallel to the longitudinal axis of the conduit. Each strip is to be cut into samples that are slightly longer than 63.5 mm (2.5 in) with each cut made in a plane perpendicular to the longitudinal axis of the strip. At least 60 such samples are required.

5.16.3 Each specimen is to be machined to the dimensions indicated in Figure 7 with the machining done only on the four cut surfaces. The end surfaces are to be flat, parallel, and in planes perpendicular to the longitudinal axis of the conduit. The longitudinal surfaces are to be flat, parallel, and in planes parallel to the longitudinal axis of the conduit. A specimen is to be discarded after this preparation when either or both of its curved surfaces show any scratches or other defects that are visible with normal or corrected to normal vision.

5.16.4 Fifteen of the machined specimens are to be set aside to be notched and then tested unaged. Forty five of the machined specimens are to be mounted with their longitudinal axes vertical in the specimen drum of carbon-arc-radiation and water-spray exposure equipment that is similar to the Type D apparatus described in ASTM G23 or G26. The specimens are to be centered between the top and bottom of the drum with the convex surface of each specimen (outside surface of the conduit) facing the axis of the drum. The drum of the apparatus used is to be 787 mm (31 in) in diameter (the diameter from the convex surface of a specimen on one side of the drum to the convex surface of a specimen on the other side of the drum is to be about 762 mm (30 in), 451 mm (17-3/4 in) high, and is to revolve at the

rate of one revolution per minute. The apparatus is to have arcs between two sets of vertical carbon electrodes that are 13 mm (1/2 in) in diameter and are individually enclosed in clear globes of heat-resistant optical glass (9200-PX pyrex glass or its equivalent), that is opaque at wavelengths shorter than 2750 angstrom units (2.75 nm) and whose transmission improves to 91 percent at 3700 angstrom units (3.70 nm). The same horizontal plane is to bisect both arcs and is to intersect each sample at its midpoint. The globes are to be replaced after whichever of the following occurs first: either 2000 hours of use or appearance in the globes of pronounced discoloration and/or milkiness. The globes are to be washed with detergent and water, rinsed thoroughly, and air dried at room temperature immediately before each day's operation.

5.16.5 Radiation from the arcs is to be kept from reaching persons within sight of the apparatus. Ventilation shall be provided to keep the products of combustion in the arcs from contaminating the samples and these products and the ozone generated are not to be in any significant concentration in the air breathed by persons.

5.16.6 Means shall be provided to enable each sample to pass through a fine spray of water once during each revolution of the drum in the cycle of 3 and 17 min repeated as noted in Clause 5.16.7. The water is to be clean, its pH is to be 6.0 – 8.0, its temperature is to be  $16.0 \pm 5.0^\circ\text{C}$  ( $60.0 \pm 9.0^\circ\text{F}$ ), and the water is not to be recirculated unless these conditions are maintained. While the arcs are in operation and the spray is off, the equilibrium black-panel temperature of the drum is to be  $63 \pm 5^\circ\text{C}$  ( $145 \pm 9^\circ\text{F}$ ).

5.16.7 With the drum revolving continuously at one revolution per minute, with the arcs operating continuously and each carrying a current of 15 – 17 A at a drop in potential of 120 – 145 V rms, and with prudent attention to the eyesight and other health risks presented by the arcs, the spray is to be operated for 3 min on and 17 min off. This cycle is to be repeated six times resulting in operation with each specimen being subjected to radiation from the arcs for a total of 102 min and to the water spray with radiation from the arcs for a total of 18 min. This sequence is to be repeated resulting, in turn, in a total elapsed operating time of 1440 hours. Fifteen of the specimens are to be removed after 720 hours, another 15 specimens are to be removed after 1080 hours, and the remaining 15 specimens are to be removed after 1440 hours. The apparatus is to be turned off for removing each set of 15 specimens, and all of the specimens are to cool to room temperature before any specimens are removed from the drum.

5.16.8 Each unaged and conditioned specimen is to be notched to the dimensions indicated in Figure 8 on a milling machine, engine lathe, or similar machine tool having an accuracy of at least 0.01 mm or 0.001 in. The cutter and feed speeds and the cutting action are to produce the notch without alteration of the conduit. Under 60 power magnification, each completed notch is to show:

- a) As a cut that is clean and sharp without any nicks, cracks, or thermal deformation and
- b) as having the angle and radius indicated in Figure 8. A micrometer having an anvil contoured to fit in the notch is to be used to verify that the depth of conduit under the notch is within the limits indicated in Figure 8. The notched surface is to be within 0.025 mm (0.001 in) of being parallel to the other long machined surface and is to have less than 0.050 mm (0.002 in) of twist. The plane bisecting the notch is to be within 2 degrees of being perpendicular to the notched surface. A specimen that departs from one or more of these requirements may be machined further to make it comply. A specimen is to be discarded after this preparation when either or both of its curved surfaces (the original inside and outside surfaces of the conduit) show any scratches or other defects. The width of each specimen retained is to be measured at the notch and recorded to the nearest 0.01 mm or 0.001 in.

5.16.9 The notched specimens are to rest in still air at a temperature of  $23.0 \pm 2.0^{\circ}\text{C}$  ( $73.4 \pm 3.6^{\circ}\text{F}$ ) for 40 hours or longer before being tested. The test is to be made within this range of temperatures.

5.16.10 The test apparatus and its calibration and A and B energy loss factors are to be in accordance with the Standard Test Methods for Determining the Pendulum Impact Resistance of Notched Specimens of Plastics, ANSI/ASTM D256.

5.16.11 At least 10 each of the unaged specimens and of the specimens prepared from samples conditioned for 720 and 1080 hours are to be tested in close succession after completion of the 1080 hours of conditioning without waiting for completion of the conditioning of the 1440 hour samples. When the results are acceptable after 1080 hours (see Table 12), conditioning of the 1440 hour samples is to be discontinued and the 1440 hour samples shall be discarded.

5.16.12 Each specimen in turn is to be positioned precisely and clamped rigidly (tightly but not to the point of damaging the specimen) in the vise as shown in Figure 9, and the pendulum is to be released. The izod impact strength of each specimen and the average izod impact strength of each group of specimens (unaged, 720 hours, 1080 hours, and possibly 1440 hours) are to be determined as described in ANSI/ASTM D256. The average izod impact strength of the unaged specimens shall not be less than 27 J/m (0.5 ft-lbf/in) of notch width (see Clause 5.16.1). The average izod impact strengths of the specimens prepared from specimens conditioned longer than 720 hours shall comply with Table 12.

## 5.17 Infrared spectroscopy

5.17.1 **General** Analysis is to be done with an infrared spectrophotometer and the results are to be recorded as a plot of the transmittance of the material to infrared radiation versus the frequency of the radiation. The plot is to be recorded over the entire wavelength range of the infrared instrument and is to be retained as a permanent record of the analysis. Identification of the specimen of interest is to be done by comparing its infrared spectrum with spectra of known materials obtained by using the same procedure dispersion element, and type of test equipment originally used.

5.17.2 **Preparation** The general technique for preparing polymers for infrared analysis is to dissolve the specimen in a boiling solvent or to selectively extract or form a thin film by compression between hot plates. In the case of dissolved thermoplastics, the resulting solution is to be placed on an optically transparent sodium chloride plate from which the solvent is evaporated by gentle heating, thereby leaving a uniform thin film of the polymer on the sodium chloride plate. The salt plate is then mounted in a spectrophotometer and the infrared spectrum of the material is to be recorded. The thin-film technique enables the specimen to be mounted directly in the spectrophotometer. The solvent-extraction method requires the formation of a potassium bromide pellet.

5.17.3 A suitable solvent is one that dissolves the material without reacting with it and that is readily evaporated on gentle heating. Examples of solvents acceptable for certain polymer types are:

- a) Acetone - for polymers of high oxygen content (eg, polyesters and phenolic resins).
- b) Ortho-dichlorobenzene - for simple vinyl-type polymers, (eg, polyvinyl chlorides).
- c) N, N - dimethylformamide - for polymers of high nitrogen content (eg, polyamides).
- d) Methylene chloride (eg, epoxies, polyesters).
- e) Trichloroethane (eg, epoxies, polyesters).

5.17.4 High-molecular-weight, highly crystalline, or cross-linked polymers that are insoluble in all volatile solvents are to be prepared by the pressed-halide-disk technique. A few milligrams of the material are to be removed from the surface of a specimen by a fine file. These filings are to be ground in a mechanical vibrating ball mill for 35 min. Care must be taken to reduce the particles to a size (approximately 2  $\mu\text{m}$ ) smaller than that of the shortest wavelength to be scanned so as to minimize scattering effects. The ground specimen is to be intimately mixed with spectroscopic grade potassium bromide, and an amount of this mixture to produce a 1 mm (0.04 in) thick, 12.7 mm (0.5 in) diameter disk is to be placed in an evacuable die. The die is to be placed under vacuum and a pressure of 69 – 103 MPa (10,000 – 15,000 lb ft/in<sup>3</sup>) is to be applied. The pressed disk is to be removed from the die and mounted in a spectrophotometer and the infrared spectrum of the material recorded.

5.17.5 **Instrumentation** The infrared spectrum from 2.0 – 15.0  $\mu\text{m}$  (wave number 5000 – 667  $\text{cm}^{-1}$ ) of a given material is to be obtained on an optical-null double-beam recording infrared spectrometer having either a diffraction grating or sodium chloride prism dispersing element.

5.17.6 **Report** The individual spectra is to be marked with each of the following:

- a) The complete identification of the material tested – including type, source, manufacturer's code, and form.
- b) Specimen preparation procedure.
- c) Spectrophotometer operating conditions.

5.18 **Tensile strength** The minimum longitudinal tensile strength of the conduit shall not be less than 62.05 MPa (9000 psi) when tested in accordance with the Standard Test Method for Longitudinal Tensile Properties of "Fiberglass" (Glass-Fiber-Reinforced Thermosetting-Resin) Pipe and Tube, ASTM D2105 with no tolerance on relative humidity.

### 5.19 Durability of printing (all types with surface-applied markings of ink, dyes, etc.)

5.19.1 **Specimen preparation** Two 300 mm (12.0 in) specimens of the finished conduit bearing the surface-applied markings shall be used.

5.19.2 **Apparatus** The apparatus shall consist of a

- a) Forced air oven and
- b) 450  $\pm$ 5 g (1  $\pm$ 0.01 lb) weight having a layer of craft felt\* approximately 1.2 mm (0.05 in) thick securely attached to a machined flat surface with dimensions of 25 by 50 mm (1.0 by 2.0 in).

\*For the purpose of this test, craft felt is defined as having not more than 30 percent wool content, the remainder being rayon.

5.19.3 **Exposure** One specimen shall be heated in a forced air oven at the temperature of 110  $\pm$ 1°C (230  $\pm$ 1.8°F) for 24 hours. The second specimen shall be maintained at room temperature for a minimum of 24 h.

5.19.4 **Procedure** Upon removal from the oven, the specimen shall be allowed to rest at room temperature for a period of 1 hour. Following the rest period, the specimen shall be laid on a solid flat surface with the printing up. The weight having the 50 mm (2 in) dimension with the attached felt shall be slid back and forth over the length of the specimen. This operation shall be repeated two more times. The time to perform the above operation shall be 5 – 10 seconds.

The same procedure shall be performed on the "as received" specimen conditioned at room temperature.

5.19.5 **Result** The printing on both specimens shall remain legible.

5.20 **Hosedown (conduit bodies)** The conduit body and its external attachments shall be subjected to a stream of water from a base having 25.4 mm (1 in) diameter nozzle which delivers 246 liters (65 gallons) per min. The water shall be directed to all connections from all angles from a distance of 3.05 – 3.65 m (10 – 12 ft) for a period of time equal to 48 (in sec.) times the test length 1.89 (H + W + D) mm or (H + W + D) in for a minimum of 5 min. A conduit shall be permitted to be installed to equalize internal and external pressures but shall not serve as a drain.

At the end of the test, the inside of the conduit body shall be examined. Water shall not have entered the conduit body.

#### 5.21 External icing (conduit bodies)

5.21.1 **Method** The conduit body shall be mounted in a room which can be cooled to -7°C (20°F). A metal test bar which is 25 mm (1.0 in) in diameter and 610 mm (24 in) long shall be mounted in a horizontal position in a location where it will receive the same general water spray as the enclosure under test.

Provision shall be made for spraying the entire conduit body from above with water at an angle of approximately 45° from the vertical. The water temperature shall be between 0°C (32°F) and 3°C (37°F). As a guide, spraying facilities which provide between 40.7 and 81.5 liters per hour per square meter (1 and 2 gallons per hour per square foot) of area to be sprayed have been found effective. The room temperature shall be lowered to 2°C (35°F). The spray of water shall be started and continued for at least 1 hour, maintaining the room temperature between 1°C (33°F) and 3°C (37°F).

At the end of this time, the room temperature shall be lowered to between 7°C (20°F) and 3°C (27°F) without discontinuing the water spray. (The rate of change in the room temperature is not critical and shall be whatever is obtainable with the cooling means employed). The water spray shall be controlled so as to cause ice to build up on the bar at a rate of approximately 6.35 mm (1/4 in) per hour and shall be continued until 19 mm (3/4 in) of ice has formed on the top surface of the bar. The spray shall then be discontinued, but the room temperature shall be maintained between 7°C (20°F) and 3°C (27°F) for 3 hours to assure that all parts of the enclosure and ice coatings have been equalized to a constant temperature.

5.21.2 **Evaluation** The conduit body and its external mechanisms shall be considered to have met the requirements of this test when:

- a) While ice laden, they can be manually operated by one person without any damage to the enclosure, the enclosed equipment, or mechanism. When an auxiliary mechanism is provided to break the ice, it shall be included and utilized in the test. A separate test is required for each maintained position of each external operator. When necessary, it shall be possible to gain access to the enclosure interior using an appropriate hand tool without causing functional damage to the enclosure.
- b) They are found to be undamaged after the ice has melted.

*Exception: Conduit bodies which do not have any external cavities to trap water when mounted in the normal position shall be considered to be acceptable and do not require testing.*

## 6 Marking

6.1 All of the markings mentioned in Clauses 6.2 to 6.4 shall be clearly legible and durable and shall comply with the requirements of CEC and NEC. Additional markings are acceptable if they do not conflict and cannot be confused with the markings covered in Clauses 6.2 to 6.4.

6.2 The outer surface of every straight length of conduit, and every elbow and other bend made from and for use with such conduit shall be marked with the following:

- a) "Reinforced Thermosetting Resin Conduit", "RTRC", or equivalent wording;
- b) The trade size (metric designator) of the conduit;
- c) The name or trademark of the manufacturer or with any other distinctive marking by means of which the organization responsible for the product can readily be identified. When desired a private labeler shall also be identified;
- d) "IPS" or "ID", as applicable;
- e) "For Use - 40°C to 110°C";
- f) "Above Ground", "AG", "Below Ground", "BG", or equivalent wording, as applicable;
- g) "FT4" when optional flame test is required for the type of conduit to be used;
- h) Expansion joints which are not subjected to the test in Clause 5.8 shall be marked, "FOR NON WATERTIGHT USAGE/NON ÉTANCHE A L'EAU."

6.3 Where the manufacturer produces conduit or elbows or fittings at more than one factory, the outer surface of each finished straight length of conduit and each elbow and fitting shall be marked with a distinctive designation (which may be in code) by means of which the conduit or fitting is identified as the product of a particular factory. The meaning of any coded identification shall be made available.

6.4 The outer surfaces of conduit and elbows, fittings and conduit bodies that are intended for wetting by reagents per Clause 5.7 shall be marked "RESISTANT TO THE FOLLOWING REAGENTS/RESISTANT AUX PRODUITS RÉACTIFS SUIVANTS"\* (name of the specific reagents and temperature limitations).

*\*French marking is required in Canada.*

## 7 In factory tests

7.1 When the inspecting authority performs in factory tests, the following tests shall be done on material taken from current production from the manufacturer:

- a) Compression test in accordance with Clause 5.2;
- b) Impact test in accordance with Clause 5.4;
- c) Dimensions in accordance with Clause 4. All tests shall be performed with the ambient temperature and relative humidity within the factory.

**Table 1**  
**Conduit dimensions – Type IPS**  
**(See Clause 4.2)**

Trade size	(metric designators)	Inside diameter minimum	Wall thickness		Outside diameter <sup>a</sup>		Out of round <sup>b</sup>
			Minimum	Maximum	Nominal	Maximum	Maximum
<b>(millimeters)</b>							
1/2	16	17.27	1.40	2.16	21.33	21.84	1.02
3/4	21	22.61	1.40	2.16	26.67	27.18	1.02
1	27	29.34	1.40	2.16	33.40	33.91	1.02
1-1/4	35	38.10	1.40	2.16	42.16	42.67	1.02
1-1/2	41	44.20	1.40	2.16	48.26	48.77	1.02
2	53	56.26	1.40	2.16	60.45	60.96	1.02
2-1/2	63	69.60	1.40	2.16	73.66	74.17	1.02
3	78	84.84	1.40	2.16	88.90	89.41	1.02
4	103	109.72	1.40	2.16	114.30	114.81	1.02
4HW	H103	109.72	1.91	2.92	115.32	115.82	1.02
5	129	136.14	1.91	2.92	141.22	142.24	1.52
6	155	162.05	1.91	2.92	168.40	169.16	1.52
<b>(inches)</b>							
1/2	16	0.680	0.055	0.085	0.840	0.860	0.040
3/4	21	0.890	0.055	0.085	1.050	1.070	0.040
1	27	1.155	0.055	0.085	1.315	1.335	0.040
1-1/4	35	1.500	0.055	0.085	1.660	1.680	0.040
1-1/2	41	1.740	0.055	0.085	1.900	1.920	0.040
2	53	2.215	0.055	0.085	2.380	2.400	0.040
2-1/2	63	2.740	0.055	0.085	2.900	2.920	0.040
3	78	3.340	0.055	0.085	3.500	3.520	0.040
4	103	4.320	0.055	0.085	4.500	4.520	0.040
4HW	H103	4.320	0.075	0.115	4.540	4.560	0.040
5	129	5.360	0.075	0.115	5.560	5.600	0.060
6	155	6.380	0.075	0.115	6.630	6.660	0.060

<sup>a</sup> Measured circumferentially.  
<sup>b</sup> Out of round is defined as maximum diameter minus minimum inside diameter.

**Table 2**  
**Conduit dimensions – Type ID**  
**(See Clause 4.2)**

Trade size	(metric designators)	Inside diameter minimum	Wall thickness		Outside diameter <sup>a</sup>		Out of round <sup>b</sup>
			Minimum	Maximum	Nominal	Maximum	Maximum
<b>(millimeters)</b>							
1/2	16	11.94	1.40	2.16	15.29	16.05	1.02
3/4	21	18.29	1.40	2.16	21.84	22.60	1.02
1	27	24.64	1.40	2.16	28.70	29.46	1.02
1-1/4	35	30.99	1.40	2.16	35.05	35.81	1.02
1-1/2	41	37.34	1.40	2.16	41.40	42.16	1.02
2	53	50.29	1.40	2.16	54.36	54.86	1.02
2-1/2	63	63.00	1.40	2.16	67.10	67.56	1.02
3	78	75.69	1.40	2.16	79.76	80.96	1.02
3-1/2	91	88.39	1.40	2.16	92.46	92.96	1.02
4	103	101.09	1.40	2.16	105.16	105.66	1.02
4HW	H103	101.09	1.91	2.92	106.43	107.19	1.52
4-1/2	116	113.79	1.91	2.92	118.62	119.38	1.52
5	129	126.24	1.91	2.92	131.82	132.59	1.52
6	155	151.64	1.91	2.92	157.23	157.99	1.52
<b>(inches)</b>							
1/2	16	0.470	0.055	0.085	0.602	0.632	0.040
3/4	21	0.720	0.055	0.085	0.860	.890	0.040
1	27	0.970	0.055	0.085	1.130	1.160	0.040
1-1/4	35	1.220	0.055	0.085	1.380	1.410	0.040
1-1/2	41	1.470	0.055	0.085	1.630	1.660	0.040
2	53	1.980	0.055	0.085	2.140	2.160	0.040
2-1/2	63	2.480	0.055	0.085	2.640	2.660	0.040
3	78	2.980	0.055	0.085	3.140	3.160	0.040
3-1/2	91	3.480	0.055	0.085	3.640	3.660	0.040
4	103	3.980	0.055	0.085	4.140	4.160	0.040
4HW	H103	3.980	0.075	0.115	4.190	4.220	0.060
4-1/2	116	4.480	0.075	0.115	4.670	4.700	0.060
5	129	4.970	0.075	0.115	5.200	5.230	0.060
6	155	5.970	0.075	0.115	6.190	6.220	0.060

<sup>a</sup> Measured circumferentially.  
<sup>b</sup> Out of round is defined as maximum inside diameter minus minimum inside diameter.

**Table 3**  
**Dimensions for couplings – Type IPS**  
**(See Clause 4.3)**

Trade size	(metric designators)	Socket depth		Inside diameter of socket		Socket wall thickness	
		minimum		minimum		minimum	
		mm	(in)	mm	(in)	mm	(in)
1/2	16	50.80	2.00	22.10	0.870	1.40	0.055
3/4	21	50.80	2.00	27.43	1.080	1.40	0.055
1	27	50.80	2.00	34.16	1.345	1.40	0.055
1-1/4	35	50.80	2.00	42.93	1.690	1.40	0.055
1-1/2	41	50.80	2.00	49.02	1.930	1.40	0.055
2	53	50.80	2.00	60.96	2.400	1.40	0.055
2-1/2	63	50.80	2.00	74.42	2.930	1.40	0.055
3	78	50.80	2.00	89.66	3.530	1.40	0.055
4	103	57.15	2.25	115.06	4.530	1.40	0.055
4HW	H103	57.15	2.25	115.06	4.530	1.40	0.055
5	129	74.68	2.94	142.49	5.610	1.91	0.075
6	155	74.68	2.94	169.04	6.655	1.91	0.075

**Table 4**  
**Dimensions for integral couplings – Type ID**  
**(See Clause 4.4.2)**

Trade size	(metric designators)	Socket depth		Inside diameter of socket		Socket wall thickness	
		minimum		minimum		minimum	
		mm	(in)	mm	(in)	mm	(in)
1/2	16	50.80	2.00	16.05	0.632	1.40	0.055
3/4	21	50.80	2.00	22.40	1.890	1.40	0.055
1	27	50.80	2.00	29.46	1.160	1.40	0.055
1-1/4	35	50.80	2.00	35.81	1.410	1.40	0.055
1-1/2	41	50.80	2.00	42.16	1.660	1.40	0.055
2	53	50.80	2.00	55.12	2.170	1.40	0.055
2-1/2	63	50.80	2.00	66.29	2.670	1.40	0.055
3	78	50.80	2.00	80.52	3.170	1.40	0.055
3-1/2	91	50.80	2.00	93.22	3.670	1.40	0.055
4	103	57.15	2.25	105.92	4.170	1.40	0.055
4HW	H103	57.15	2.25	105.92	4.230	1.40	0.055
4-1/2	116	74.68	2.94	119.63	4.710	1.40	0.055
5	129	74.68	2.94	132.84	5.230	1.91	0.075
6	155	74.68	2.94	158.24	6.230	1.91	0.075

**Table 5**  
**Radius of bends**  
**(See Clause 4.4.2)**

Trade size of conduit (metric designators)	Minimum radius R of bend to centerline of conduit,	
	mm	(in)
1/2 (16), 3/4 (21), 1 (27), 1-1/4 (35), 1-1/2 (41), 2 (53)	305	12
2-1/2 (63), 3 (78), 3-1/2 (91)	610	24
4 (103), 4HW (H103)	914	36
4-1/2 (116), 5 (129), 6 (155)	1219	48

**Table 6**  
**Threaded adapter and threaded box connector**  
**(See Clause 4.5.1)**

Trade size	(metric designators)	Socket depth,		Minimum inside diameter	
		mm	(in)	mm	(in)
1/2	16	50.8	2	12.2	0.42
3/4	2	50.8	2	18.5	0.73
1	27	50.8	2	24.9	0.96
1-1/4	35	50.8	2	31.2	1.23
1-1/2	41	50.8	2	36.8	1.48
2	53	50.8	2	50.3	1.98
2-1/2	63	50.8	2	63.0	2.48
3	78	50.8	2	75.7	2.98
3-1/2	91	50.8	2	88.4	3.48
4	103	57.2	2.25	101.1	3.98
4HW	103	57.2	2.25	101.1	3.98
4-1/2	116	74.7	2.94	113.79	4.48
5	129	74.7	2.94	126.5	4.98
6	155	74.7	2.94	151.9	5.98

Note: Threaded adapter national pipe thread (NPT). Threaded box connector national pipe thread straight (NPTS).

**Table 7**  
**Force for compression test**  
**(See Clause 5.2)**

Trade size	(metric designation)	Force	N(lbf)
1/2	16	4450	1000
3/4	21	4450	1000
1	27	4450	1000
1-1/4	35	4450	1000
1-1/2	41	4450	1000
2	53	2800	650
2-1/2	63	2200	500
3	78	1780	400
3-1/2	91	1340	300
4	103	980	220
4HW	H103	2000	450
4-1/2	116	1850	415
5	129	1780	400
6	155	1780	400

**Table 8**  
**Beam strength test**  
**(See Clause 5.3)**

Trade size	(metric designators)	Specimen length,		Free span between blocks,		Minimum initial yield force,	
		mm	(in)	mm	(in)	N	(lbf)
1/2	16	500	20.0	305	12.0	200	45
3/4	21	500	20.0	305	12.0	400	90
1	27	500	20.0	305	12.0	600	135
1-1/4	35	500	20.0	305	12.0	800	180
1-1/2	41	500	20.0	305	12.0	1100	247
2	53	500	20.0	305	12.0	2110	474
2-1/2	63	500	20.0	305	12.0	2225	500
3	78	750	29.5	610	24.0	1625	365
3-1/2	91	750	29.5	610	24.0	2560	575
4	103	750	29.5	610	24.0	2445	549
4HW	H103	750	29.5	610	24.0	3115	700
4-1/2	116	750	29.5	610	24.0	3115	700
5	129	750	29.5	610	24.0	4000	899
6	155	750	29.5	610	24.0	4450	1000

**Table 9**  
**Impact resistance**  
**(See Clause 5.4)**

Trade size	(metric designators)	Impact force	
		J	ft.lbs
1/2	16	20	15
3/4	21	20	15
1	27	20	15
1-1/4	35	20	15
1-1/2	41	27	20
2	53	54	40
2-1/2	63	61	45
3	78	80	60
3-1/2	91	80	60
4	103	80	60
4HW	H103	110	80
4-1/2	116	110	80
5	129	140	100
6	155	140	100

**Table 10**  
**Maximum vertical deflection of the diameter on the**  
**resistance to flattening test**  
**(See Clause 5.10)**

Table 10 revised March 17, 2000

Trade size	(metric designation)	Maximum vertical deflection of diameter,	
		mm	(in)
1/2	16	1.28	0.050
3/4	21	1.53	0.060
1	27	1.78	0.070
1-1/4	35	2.16	0.085
1-1/2	41	2.55	0.100
2	53	2.93	0.115
2-1/2	63	6.61	0.260
3	78	9.83	0.387
3-1/2	91	15.62	0.615
4	103	25.63	1.010
4HW	H103	11.43	0.450
4-1/2	116	11.43	0.450
5	129	15.24	0.600
6	155	24.38	0.960

**Table 11**  
**Tray loading**  
**(See Clause 5.13.10)**

Conduit outside diameter mm (in)				Number of conduits in tray
From		To		
0	0	15.0	0.59	11
15.1	0.59	19.0	0.75	9
19.1	0.75	21.0	0.83	8
21.1	0.83	26.0	1.02	7
26.1	1.03	28.0	1.10	6
28.1	1.11	39.0	1.54	5
39.1	1.54	52.0	2.05	4
52.1	2.05	73.0	2.87	3
73.1	2.88	120.0 <sup>1</sup>	4.72	2

<sup>1</sup>The tray flame test provides some indication of the performance of grouped conduits. Therefore, even with larger specimens, there should be at least two conduits to allow for heat reflection and interaction between specimens.

**Table 12**  
**Weather resistance**  
**(See Clause 5.16)**

Average izod impact strength of unaged specimens	Conditioning period in hours, carbon (xenon)	Percent decrease in average izod impact strength at the end of the conditioning period indicated in the previous column	Acceptability of conduit
27 – 81 J/m of notch width	0 – 720 (0 – 1000)	–	No requirement <sup>a</sup>
	0.5 – 1.5 ft-lbf/in of notch width)	720 – 1080	0 – 5
(1000 – 1500)		Over 5 but under 7.5	Not acceptable unless specimens comply after 1440 h (carbon) or 2000 h (xenon)
1080 – 1440 <sup>b</sup>		0 – 5	Acceptable
(1500 – 2000)		Over 5	Not acceptable
Over 81 J/m of notch width	0 – 720	–	No requirement <sup>a</sup>
	0 – 1000	0 – 10	Acceptable
(Over 1.5 ft-lb/in of notch width)	720 – 1080	Over 10 but under 15	Not acceptable unless specimens comply after 1440 h <sup>b</sup> (carbon) or 2000 h (xenon)
	(1000 – 1500)		Acceptable
	1080 – 1440 <sup>b</sup>	0 – 10	Acceptable
	(1500 – 2000)	Over 10	Not acceptable

<sup>a</sup> The average izod impact strength after conditioning for 720 h to carbon arc or 1000 h to xenon arc is to be used as the basis against which the average izod impact strength after longer conditioning is compared.

<sup>b</sup> Completion of the conditioning of specimens for test after the 360 h period of 1080 – 1440 h may be discontinued if the percentage decrease in the average izod impact strength is acceptable for specimens conditioned for 720 – 1080 h.

Figure 1 – Conduit elbows  
(See Clause 4.4)

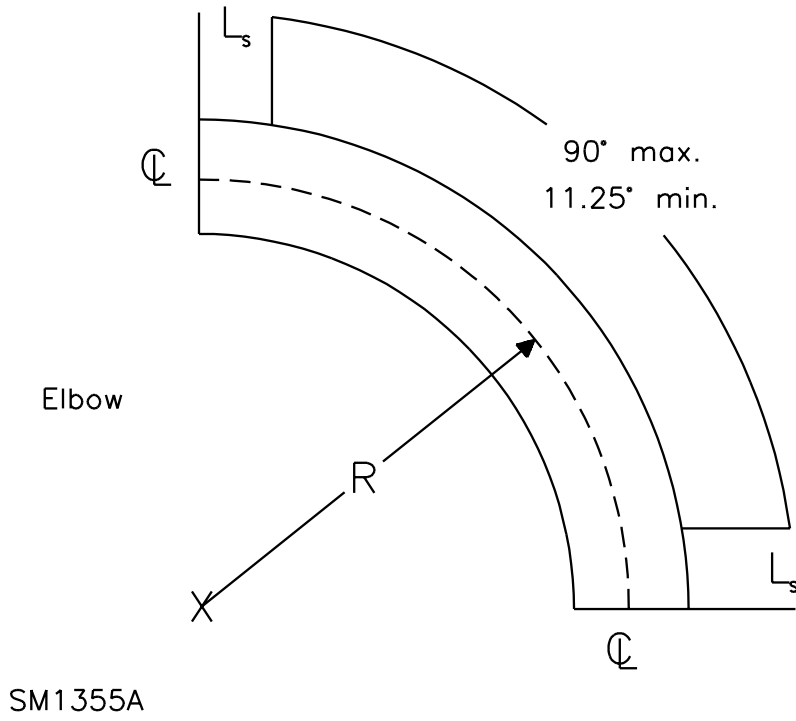
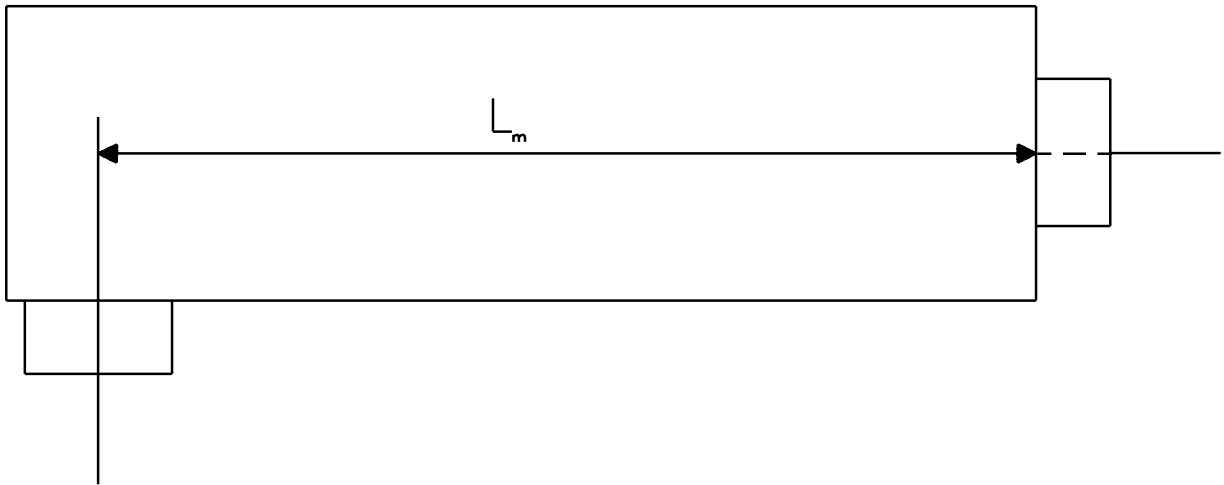
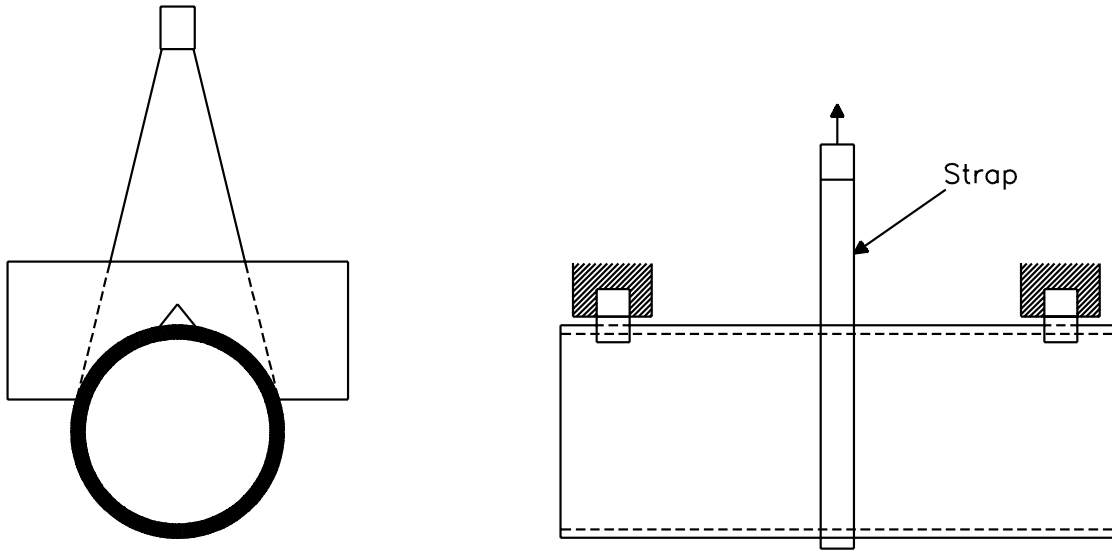

Figure 2 – Capacity of conduit body  
(See Clause 4.6.3)



SM1356

Figure 3 – Beam strength test apparatus  
(See Clause 5.3)



SM1366

Figure 4 – Impact – tup geometry  
(See Clause 5.4.3)

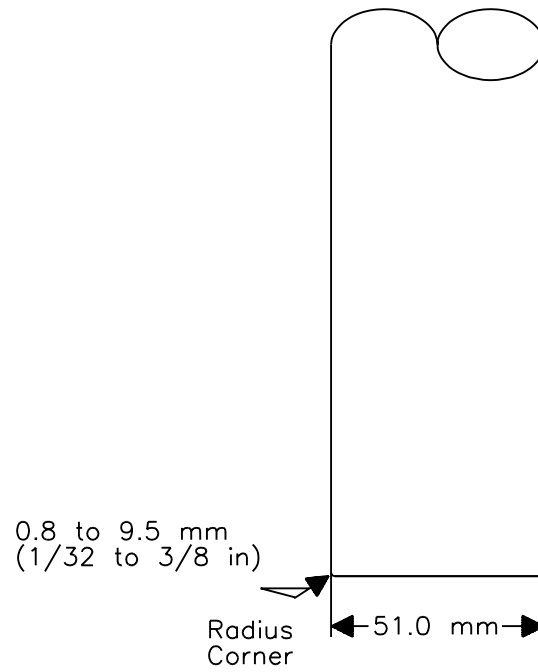

SM1367

**Figure 5 – Static load test bed for flattening resistance test  
(See Clause 5.10)**

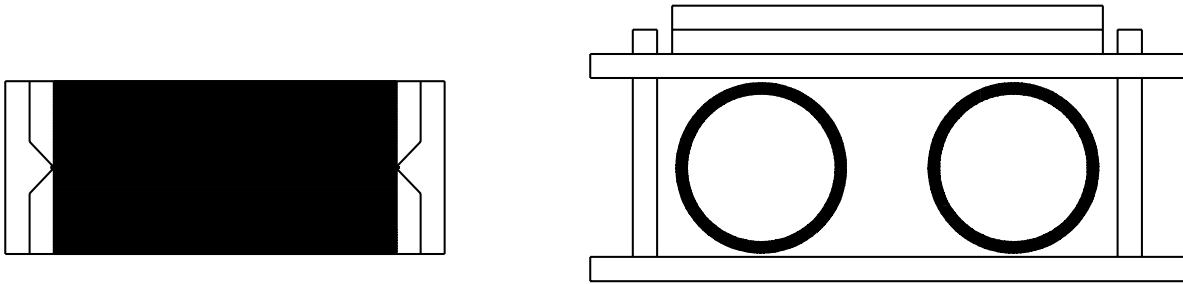

Note: The test mass includes the mass of the upper platen.

SM1368

**Figure 6 – Mandatory flame test  
(See Clause 5.12)**

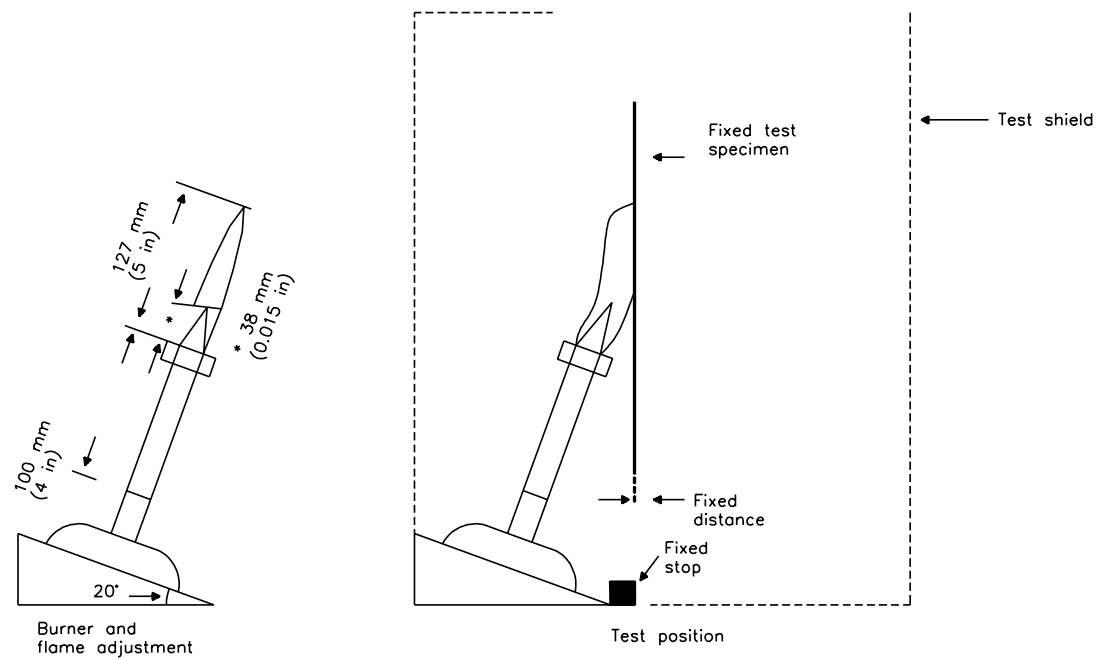

SM1369

**Figure 7 – Machined sample before conditioning  
(See Clause 5.16.3)**

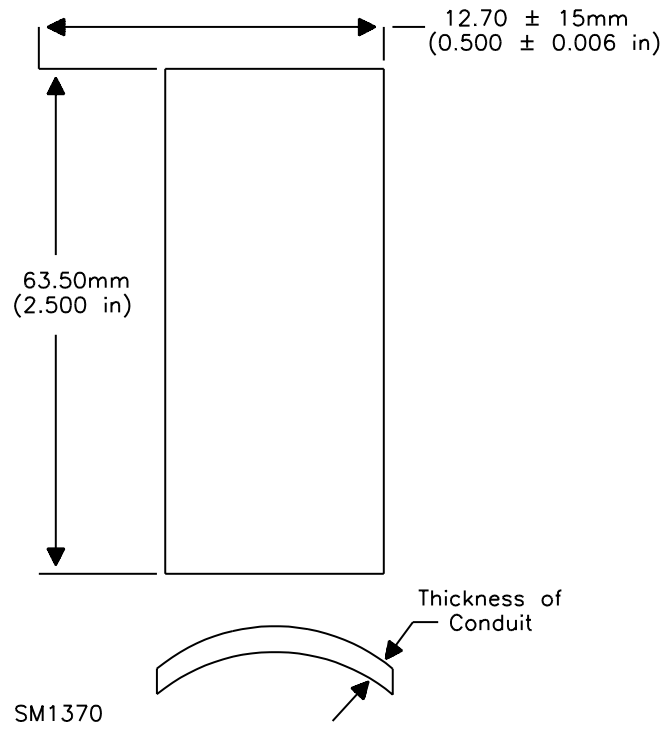

Figure 8 – Specimens showing notch  
(See Clause 5.16.8)

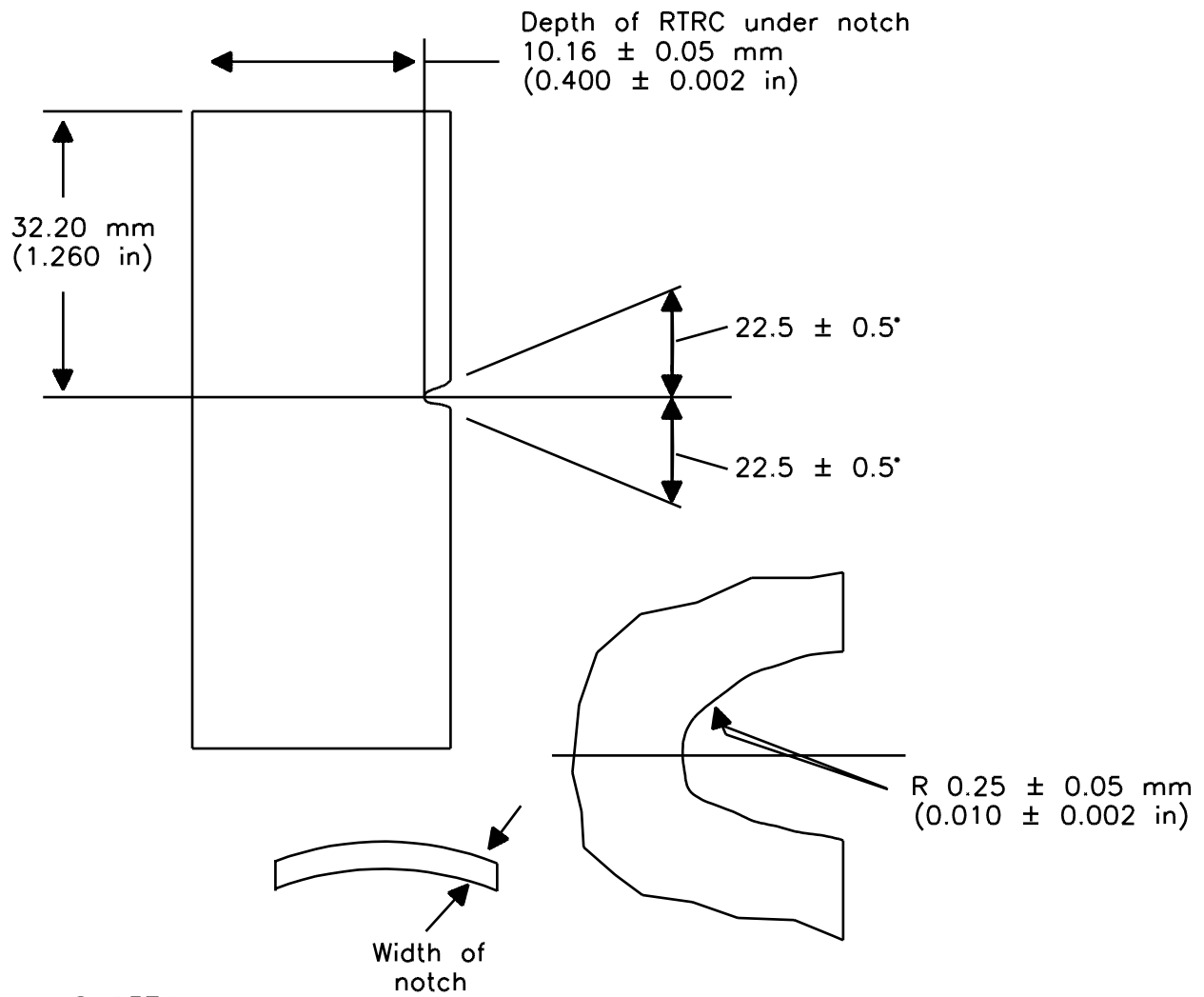
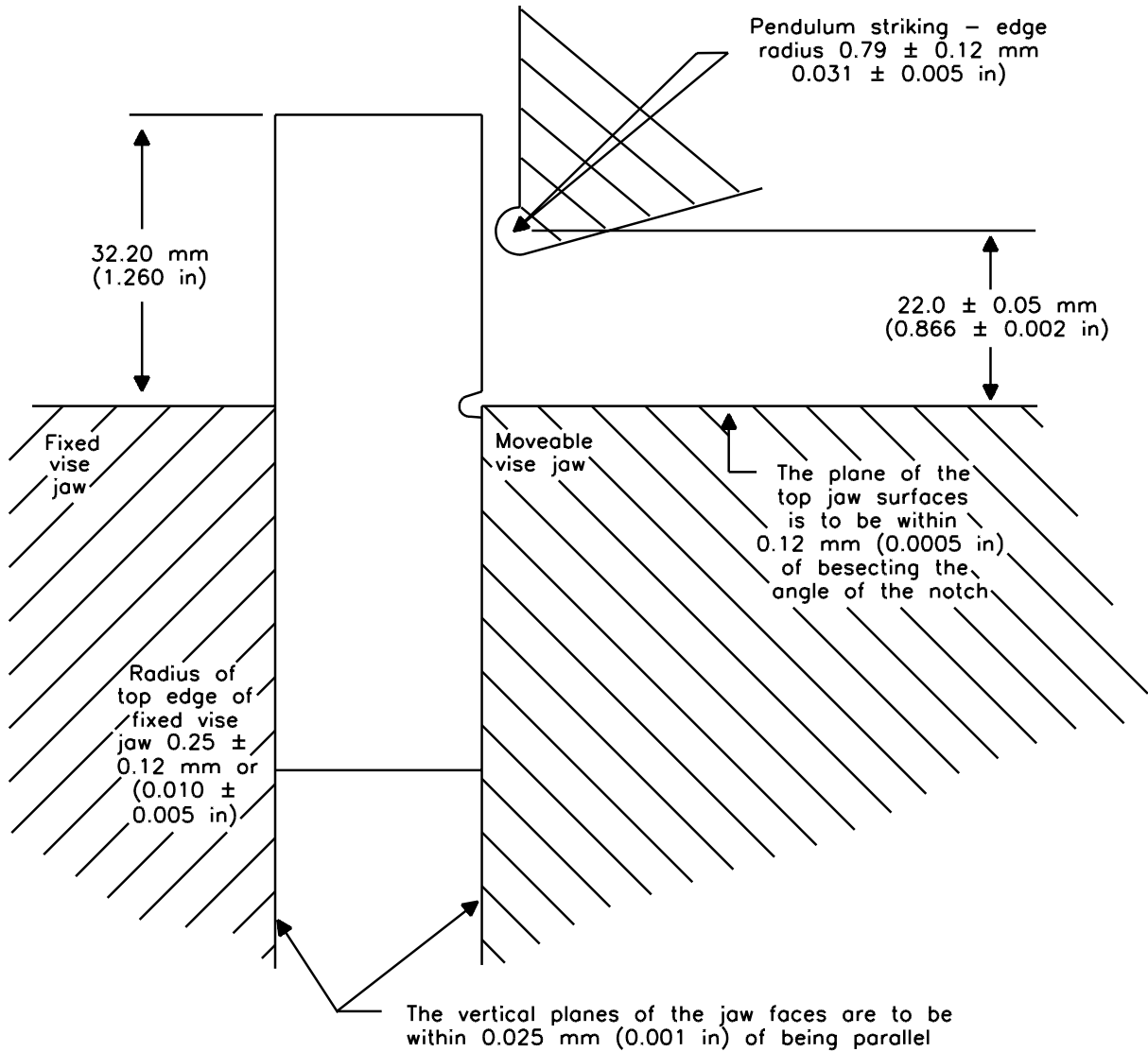

Figure 9 – Positioning of IZOD impact test  
(See Clause 5.16.12)



SM1372

## Appendix A – Guidelines

*Note: This Appendix is not a mandatory part of this Standard.*

A1 Proper joint selection should be specified by end user based on application.

A2 FT4 flame test is a Canadian national building requirement in a designated non-combustibility building.

### A3 Intake airflow

#### A3.1 Natural airflow

A3.1.1 The openings described in Clauses A3.1.2 and A3.1.3 have been found to be suitable to produce an acceptable airflow of approximately 10 m<sup>3</sup>/min under natural airflow conditions.

A3.1.2 A fresh air intake opening of area  $0.05 \pm 0.005 \text{ m}^2$  shall be provided in a wall of the enclosure. The opening shall be of a shape such that no dimension is more than 0.4 m. No portion of the intake opening may be more than 0.3 m above the floor of the enclosure or less than 0.8 m horizontally from an adjacent wall surface.

A3.1.3 An air and smoke exhaust opening shall be provided in the top of the enclosure of area  $0.37 \pm 0.02 \text{ m}^2$ . No portion of the exhaust opening may be less than 4 m above the floor of the enclosure.

A3.2 **Forced airflow** The forced airflow should be sufficient to ensure that the flame is clearly visible throughout the test. The minimum airflow should be 10 m<sup>3</sup>/min to maintain appropriate oxygen levels.

A4 **Trays** The conduit and tubing are installed in ladder-type cable trays in order to standardize the testing.

---

## Appendix B – Method to determine the halogen content of a low halogen material using the calculation method from pH and Acid Gas Evolution

B1 This test determines the acid gas evolution from the pyrolysis of nonmetallic component materials where the resultant solution has a pH value greater than 3.26 (less than 4 percent acid gas when calculated as HCl). This test is acceptable for materials containing low levels of acid gas. The method is not recommended for fluoropolymer material.

B2 Acid gas content is determined by a pH measurement.

### B3 Test equipment

B3.1 **General** The test equipment shall consist of a tube furnace, a combustion tube, and a combustion boat to hold the sample. The acid gas by-products released during the pyrolysis of the sample are absorbed by the water in water traps.

B3.2 **Equipment layout** The test equipment layout is shown in Figure B1 and consists of the following:

- a) Three water traps approximately 25 by 200 mm (1 by 8 in) in size;
- b) A quartz glass combustion tube<sup>x</sup> fitted with ground glass connections at the discharge end, having an internal diameter of approximately 25 mm (1 in), a minimum length of two times the length of the furnace, and a preferred length of 700 to 900 mm (27.6 to 35.4 in);
- c) Glass tubing and stoppers or ground glass joints to connect the water traps;
- d) A glazed porcelain combustion boat with the following inside dimensions: length 75 mm (2.95 in), width 10 mm (0.39 in), and depth 9 mm (0.35 in); new combustion boats shall be pre-fired before use in a muffle furnace for at least 2 hours at the test temperature; used combustion boats shall be treated the same as new boats and shall be used for not more than 8 tests;

#### Notes:

1) Used boats may result in lower values.

2) When the quartz combustion tube is used for conditioning the boats, the tube shall be heated for its full length to ensure that all foreign materials accumulated have been vaporized.

- e) A tube furnace<sup>y</sup> capable of a maximum temperature of 1200°C (2192°F) with a length of not less than four times the inside length of the combustion boat and a preferred length of 300 to 400 mm (11.8 to 15.7 in);
- f) A potentiometer equipped with a thermocouple (Type K);
- g) An air flow meter with a range of 0-200 mL/min (0 - 0.053 gal/min);
- h) High temperature heating tape capable of maintaining a minimum of 150°C (302°F) on the surface of the glass tube;
- i) Water of pH 5 to 7 and a maximum conductivity of 10 µS/cm;
- j) Commercially available bottled air;
- k) A ceramic wool plug<sup>z</sup>;

- l) A pH meter having a minimum precision of  $\pm 0.01$  pH units; and
- m) A calibrated 1 liter volumetric flask.

<sup>x</sup>The quartz glass combustion tube, or the entire glass assembly, supplied by LaSalle Glass Blowing, 121 Malcolm Road, Guelph, Ontario, Canada, has been found suitable.

<sup>y</sup>The Lindberg Model 55035, approximately 300 mm (11.8 in) long, has been found suitable.

<sup>z</sup>The Carborundum Fiberfrax Durablanket S 8#, at a surface density of approximately  $40 \text{ kg/m}^2$  ( $8 \text{ lb/ft}^2$ ) and a thickness of 6 mm (0.24 in), has been found suitable. A supplier is Niagara Carborundum, 2351 Whirlpool Street, Niagara Falls, New York 14302.

## B4 Test procedure

**B4.1 Sample preparation** Cut a specimen having a total mass of  $0.5 \pm 0.05 \text{ g}$  ( $0.018 \pm 0.002 \text{ oz}$ ) with a length suitable for the size of the combustion boat.

**B4.2 Apparatus assembly** The procedure for assembly of the apparatus is as follows:

- a) Pour water into each water trap to a minimum of 100 mm (3.93 in) above the bubble outlet.
- b) The combustion tube is placed in the furnace.
- c) Connect the water traps and the combustion tube.
- d) Connect the combustion tube to the variable air flow. Adjust the air flow between 100 and 125 mL/min (0.027 to 0.033 gal/min), until the air is bubbling through the water traps. The air flow measurement shall be taken after the last water trap.
- e) Disconnect the water traps from the combustion tube and insert a suitable thermocouple into the combustion tube at the midpoint of the furnace. Adjust the furnace powerstat to obtain an air temperature inside the combustion tube of  $800 \pm 10^\circ\text{C}$  ( $1472 \pm 18^\circ\text{F}$ ). (This must be done with the air flowing.) Remove the thermocouple after the temperature inside the tube has stabilized.

*Note: Temperature control is critical.*

- f) At the end opposite the air inlet, insert a snug fitting ceramic wool plug approximately 25 mm long into the combustion tube to a position just at the start of the furnace. The plug will trap solid combustion products and prevent carryover into the water traps. The residue, which occasionally contains attached acid gases, will be burnt off at the last stage (see Figure B1(c)).
- g) Remove the combustion tube from the variable air flow and reconnect the water traps to the combustion tube.
- h) On the end of the tube opposite the air inlet, wrap a heating tape around the glass tubing connecting the combustion tube to the first water trap and around the tube for a length of approximately 100 mm (4 in) (see Figure B1(a)). The heating tape prevents combustion products from condensing on the unheated portion of the combustion tube and on the tube leading to the first water trap. Adjust the powerstat for the heating tape to obtain a minimum glass surface temperature of  $150^\circ\text{C}$  ( $302^\circ\text{F}$ ).

i) At the air inlet end, insert the combustion boat containing the sample specimen into the combustion tube just at the start of the furnace. The direction by which the sample is introduced is critical (see Figure B1(a)).

j) Reconnect the combustion tube to the variable air flow, maintaining the initial air flow.

*Notes:*

1) Calibration of temperature and air flow shall be performed at a frequency which ensures that the specified requirements are met.

2) Evolved gases from the last water trap are to be safely exhausted.

3) Prior to use, the pH meter should be calibrated in the pH range of 3 to 4.

**B4.3 Acid gas evolution** The procedure is as follows:

a) In six moves, slide the furnace along the combustion tube to locate the specimen in the center of the furnace (see Figure B1(b)). The first three moves shall be 25 mm (1 in) each, with three further moves taking the specimen to the center of the furnace. The time intervals between moves shall be 1 min.

b) In six moves, slide the furnace along the combustion tube to locate the specimen in the center of the furnace (see Figure B1(b)). The first three moves shall be 25 mm (1 in) each, with three further moves taking the specimen to the center of the furnace. The time intervals between moves shall be 1 min.

c) Combine the water from the traps and thoroughly wash the tubing connections and the traps with water into the 1 liter flask. Add water to the combined washings to achieve a total volume of 1 liter at  $23 \pm 5^{\circ}\text{C}$  ( $73 \pm 9^{\circ}\text{F}$ ).

**B4.4 Acid gas measurement**

B4.4.1 The pH measurement will be made on the solution taken from the 1 liter flask.

B4.4.2 **Number of tests** The acid gas evolution test shall be conducted a minimum of three times and the average value shall be used to determine the amount of acid gas evolved. No individual results shall differ from the average value by more than 10 percent.

B4.4.3 When the average value is found to be greater than a pH of 4.0, no individual result shall differ from the average value by more than 20 percent.

*Note: For the purpose of this procedure, the acid gas (as % HCl) equivalents are shown in Clause B5 using 0.5 gm of material with 1 liter of water.*

**B5 Determination of halogen content**

pH to Acid gas		pH to Acid gas		Acid gas to pH		Acid gas to pH	
pH	% Acid gas	pH	% Acid gas	% Acid gas	pH	% Acid gas	pH
0.1	5792.2	3.6	1.8	0.1	4.56	3.5	3.32
0.2	4600.9	3.7	1.5	0.2	4.56	3.6	3.31
0.3	3654.7	3.8	1.2	0.3	4.39	3.7	3.29
0.4	2903.0	3.9	0.9	0.4	4.26	3.8	3.28
0.5	2305.9	4.0	0.73	0.5	4.16	3.9	3.27
0.6	1831.7	4.1	0.58	0.6	4.08	4.0	3.26
0.7	1454.9	4.2	0.46	0.7	4.02	4.1	3.25
0.8	1155.7	4.3	0.37	0.8	3.96	4.2	3.24
0.9	918.0	4.4	0.29	0.9	3.91	4.3	3.23
1.0	729.2	4.5	0.23	1.0	3.56	4.4	3.22
1.1	579.2	4.6	0.18	1.1	3.82	4.5	3.21
1.2	460.1	4.7	0.15	1.2	3.75	4.6	3.20
1.3	365.5	4.5	0.12	1.3	3.75	4.7	3.19
1.4	290.3	4.9	0.09	1.4	3.72	4.8	3.18
1.5	230.6	5.0	0.07	1.5	3.69	4.9	3.17
1.6	183.2	5.1	0.08	1.6	3.66	5.0	3.16
1.7	145.5	5.2	0.05	1.7	3.63	5.1	3.16
1.8	115.6	5.3	0.04	1.8	3.61	5.2	3.15
1.9	91.8	5.4	0.03	1.9	3.58	5.3	3.14
2.0	72.9	5.5	0.02	2.0	3.56	5.4	3.13
2.1	57.9	5.6	0.018	2.1	3.54	5.5	3.12
2.2	46.0	5.7	0.015	2.2	3.52	5.6	3.11
2.3	38.5	5.8	0.012	2.3	3.50	5.7	3.11
2.4	29.0	5.9	0.009	2.4	3.48	5.8	3.10
2.5	23.1	6.0	0.007	2.5	3.46	5.9	3.09
2.6	18.3	6.1	0.008	2.6	3.45	6.0	3.06
2.7	14.5	6.2	0.005	2.7	3.43	6.1	3.06
2.8	11.6	6.3	0.004	2.8	3.42	6.2	3.07
2.9	9.2	6.4	0.0029	2.9	3.40	6.3	3.06
3.0	7.3	6.5	0.0023	3.0	3.39	6.4	3.06
3.1	5.8	6.6	0.0018	3.1	3.37	6.5	3.05
3.2	4.6	6.7	0.0015	3.2	3.36	6.6	3.04
3.3	3.7	6.8	0.0012	3.3	3.34	6.7	3.04
3.4	2.9	6.9	0.0009	3.4	3.33	6.8	3.03
3.5	2.3	7.0	0.0007	3.5	3.32	6.9	3.02

Figure B1 – Acid gas evolution test  
(See Clauses B4.2 and B4.3)

a) Position at start of test

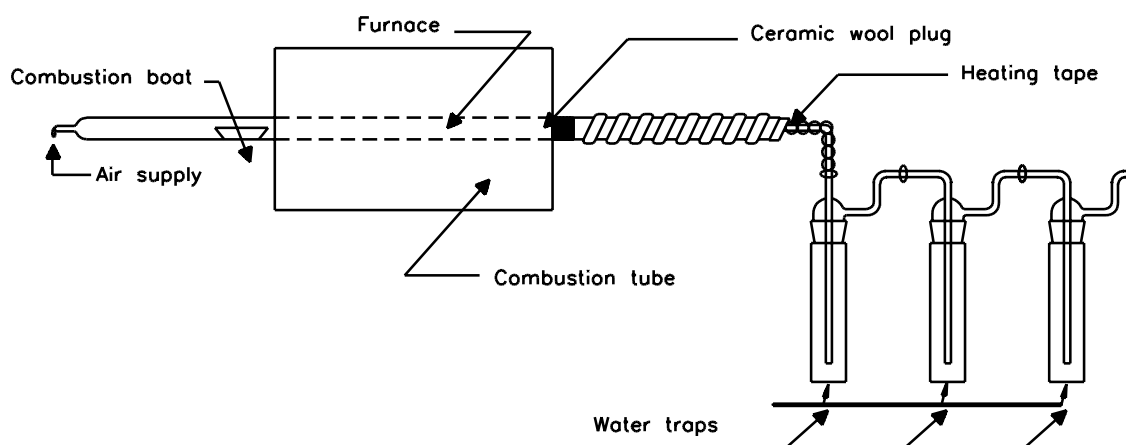

b) Position during test

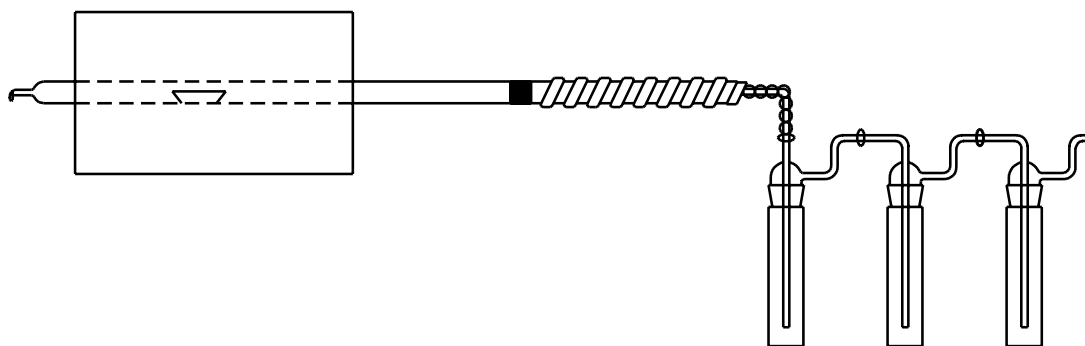

c) Position to burn off residue

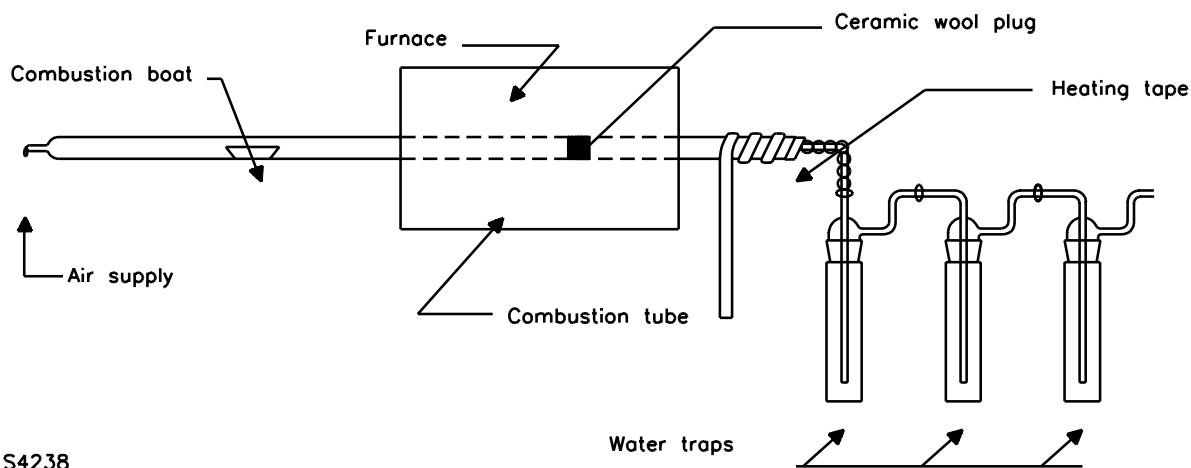

Subject 1684

1655 Scott Blvd.  
Santa Clara, CA 95050  
April 4, 1996

**TO: Electrical Council of Underwriters Laboratories Inc.  
Subscribers to UL's Standards Service for  
Reinforced Thermosetting Resin Conduit**

**SUBJECT: Announcement of UL's Acceptance of Schedule 40 and Schedule 80 Conduit for  
Investigation using the Standard for Reinforced Thermosetting Resin Conduit, UL  
1684**

UL announces that it is prepared to accept submittals of Rigid Nonmetallic Fiberglass Conduit (DZKT) which meet the dimensional requirements for either Schedule 40 or Schedule 80 conduit. UL has determined that products complying with these dimensions meet the intent of the construction requirements in UL 1684.

Products which are determined to comply with the performance requirements in UL 1684, and which have the dimensions of Schedule 40 or 80 conduit will be eligible to bear the UL Listing Mark for Rigid Nonmetallic Fiberglass Conduit.

This bulletin should be kept with your copy of the standard.

Questions regarding interpretation of requirements should be directed to the responsible UL Staff. Please see Appendix A of this bulletin regarding designated responsibility for the subject product category.

UNDERWRITERS LABORATORIES INC.

REVIEWED BY:

WILLIAM C. WAGNER (Ext. 22470)  
Engineering Team Leader  
Engineering Services 216T  
MELVILLE OFFICE  
(516) 271-6200

ROBERT LA ROCCA (Ext. 22598)  
Associate Managing Engineer  
Engineering Services 216T  
MELVILLE OFFICE  
(516) 271-6200

SR:RM

1684\_\_\_\_.44B

APPENDIX A

DESIGNATED RESPONSIBILITY FOR UL PRODUCT CATEGORY

DZKT, RIGID NONMETALLIC FIBERGLASS CONDUIT

The individuals shown in the following table are involved with the investigation of products covered under the subject category. The Primary Designated Engineer (**shown in UPPERCASE letters**) coordinates the establishment and uniform interpretation of UL requirements applicable to the product category. The Designated Engineers (**shown in lowercase letters**) work with the Primary Designated Engineer to interpret requirements and maintain standards.

Should you have questions regarding the interpretation of any adopted requirements that affect your product, you are encouraged to contact the individual at the office to which you normally submit your products.

The Responsible Department Manager for the subject category is Cliff Jones at UL's Melville office. The Responsible Department Manager oversees the significant interpretations made by the Primary Designated Engineer and arbitrates any differences regarding interpretation of UL requirements.

CCN	Office/Subsidiary	Responsible Engineer	Extension
DZKT	Melville	GLENN RUSINSKI	22670
	Northbrook	Margo Torroll	43032
	RTP	Isaac Clark	1608
	Santa Clara	Susan Stene	32948