

Specifications for Fiberglass Hangers

This specification details the requirements for hangers (suspension supports) used to support fiberglass conduit from bridge structures.

The hangers shall be shipped fully assembled with all necessary components. All nuts shall be tightened to “snug fit”.

The fiberglass components shall be manufactured using isophthalic polyester resin and contain UV inhibitors. They shall contain a fire retardant and exhibit low smoke generation. The fiberglass components shall be gray in color and shall meet or exceed the following.

Fiberglass Square Tube, Flat Bar and Round Spacer Tube

Mechanical Properties	ASTM	English		Metric	
		Value	Units	Value	Units
Tensile Strength	D638	30,000	psi	206.8	MPa
Tensile Modulus	D638	2.5 x 10 ⁶	psi	17.2	GPa
Compressive Strength	D695	30,000	psi	206.8	MPa
Compressive Modulus	D695	2.5 x 10 ⁶	psi	17.2	GPa
Flexural Strength	D790	30,000	psi	206.8	MPa
Flexural Modulus	D790	1.8 x 10 ⁶	psi	12.4	GPa
Modulus of Elasticity		2.8 x 10 ⁶	psi	19.3	GPa
Shear Modulus		0.45 x 10 ⁶	psi	3.1	GPa
Short Beam Shear	D2344	4,500	psi	31.0	MPa
Punch Shear	D256	10,000	psi	68.9	MPa
Impact Strength	D256	25	ft-lbs/in	1.33	J/mm

Physical Properties	ASTM	English		Metric	
		Value	Units	Value	Units
Barcol Hardness	D2583	45			
24 Hour Water Absorption	D570	0.45%	max		
Density	D792	.062-.070	lbs/in ³	1.72-1.94	g/cc
Coefficient of Thermal Expansion	D696	4.4	10 ⁻⁶ in/in/°F	8	10 ⁻⁶ cm/cm/°C

Electrical Properties	ASTM	English		Metric	
		Value	Units	Value	Units
Arc Resistance	D495	120	seconds		
Dielectric Strength	D149	35	kv/in	1.37	kv/mm

Flammability Properties	ASTM	English	
		Value	Units
Tunnel Test	E84	25	max
Flammability	D635	Nonburning	
UL	94	VO	
Smoke Chamber	E662	600-700	

Hangers are designed and fabricated in such manner as to eliminate the possibility of crushing the square tube by tightening the nuts on the suspension or intermediate rods (the spacer tube shall rest on the bottom part of the square tube).

Steel Hardware Specifications

The support rods, intermediate rods, and all metallic hardware will be manufactured as **Hot Dipped Galvanized Steel, 304 Stainless Steel** or **316 Stainless Steel**. These hanger components are assembled based on the specified application requirements.

Complete components of a bridge hanger may include the following:

- 2" x ½" (**50.8mm x 12.7mm**) Fiberglass flat bar, all holes on centerline, holes for support rods, 1" (**25mm**) from each end of plate. Length as required.
- 2" x 2" x ¼" (**50.8mm x 50.8mm x 6.4mm**) Fiberglass square tubing, all holes on centerline, holes for support rods, 1" (**25mm**) from each end of square tube. Length as required.
- 1" OD x 0.755" ID (**25.4mm OD x 19.2mm ID**) Fiberglass spacer tube. Length as required.
- ¾" (**19mm**) All thread rod with 2 nuts, 2 lock washers and 2 flat washers. Length as required.

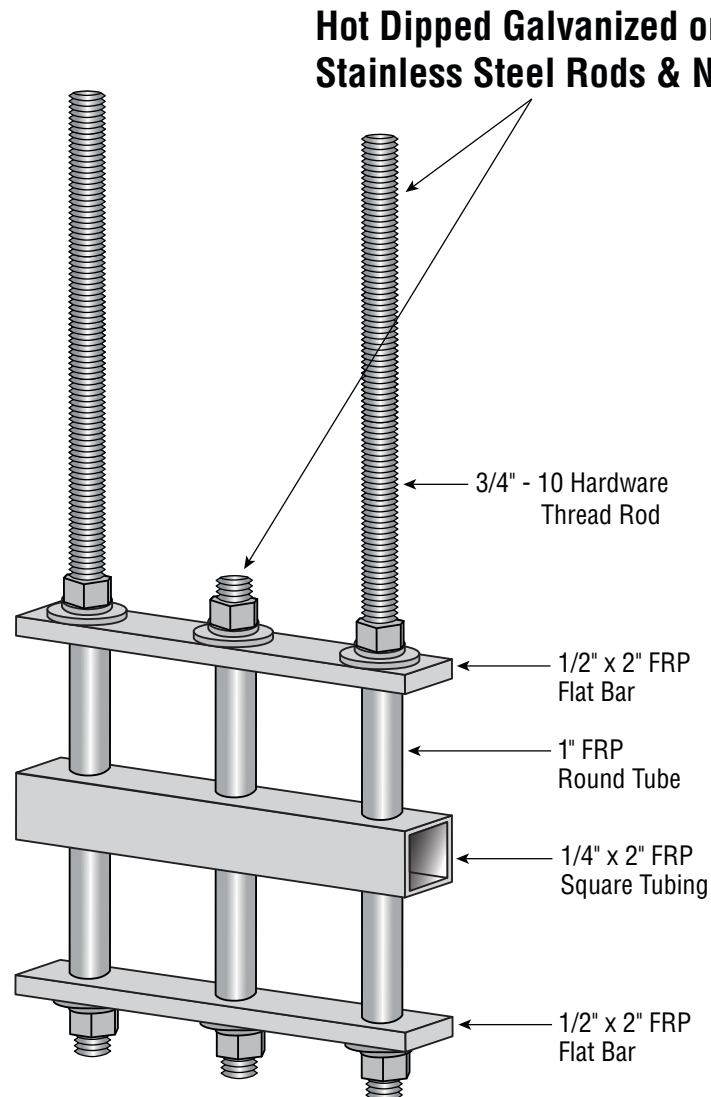

Hot Dipped Galvanized Hardware

The support rods, intermediate rods, and all metallic hardware shall be hot dipped galvanized steel and shall meet or exceed the following:

- Threaded Rod ASTM A307 with ASTM 153 Galvanizing Tensile Strength 74,000 psi
- Hex nut ASTM A307 with ASTM 153 Galvanizing
- Flat washer ASTM A307 with ASTM 153 Galvanizing
- Lock washer ASTM A307 with ASTM 153 Galvanizing

Metal components that are custom fabricated shall have a hot dipped galvanizing applied in accordance with ASTM specification a-123/123m2 dated 2002 with a minimum coating thickness of 2.0 oz/sq ft. The zinc used in this process shall be a high grade zinc conforming to ASTM B6-00 with less than .03% lead used in this process.

304 Stainless Steel Hardware

The support rods, intermediate rods, and all metallic hardware shall be stainless steel and shall meet or exceed the following:

- Threaded Rod SS304 ASTM A193 grade B8
- Hex nut ASTM SS304 A194 grade 8
- Flat washer SS18-8
- Lock washer SS18-8

Metal components that are custom fabricated shall be stainless steel 304 in accordance with ASTM specification A193/A193M-94b dated 1994.

316 Stainless Steel Hardware

The support rods, intermediate rods, and all metallic hardware shall be stainless steel and shall meet or exceed the following:

- Threaded Rod SS316 ASTM A193 grade B8M
- Hex nut ASTM SS316 A194 grade 8M
- Flat washer SS18-8
- Lock washer SS18-8

Metal components that are custom fabricated shall be stainless steel 316 in accordance with ASTM specification A193/A193M-94b dated 1994.

NOTE: A completed bridge hanger also include components referenced at the beginning of this section.*